

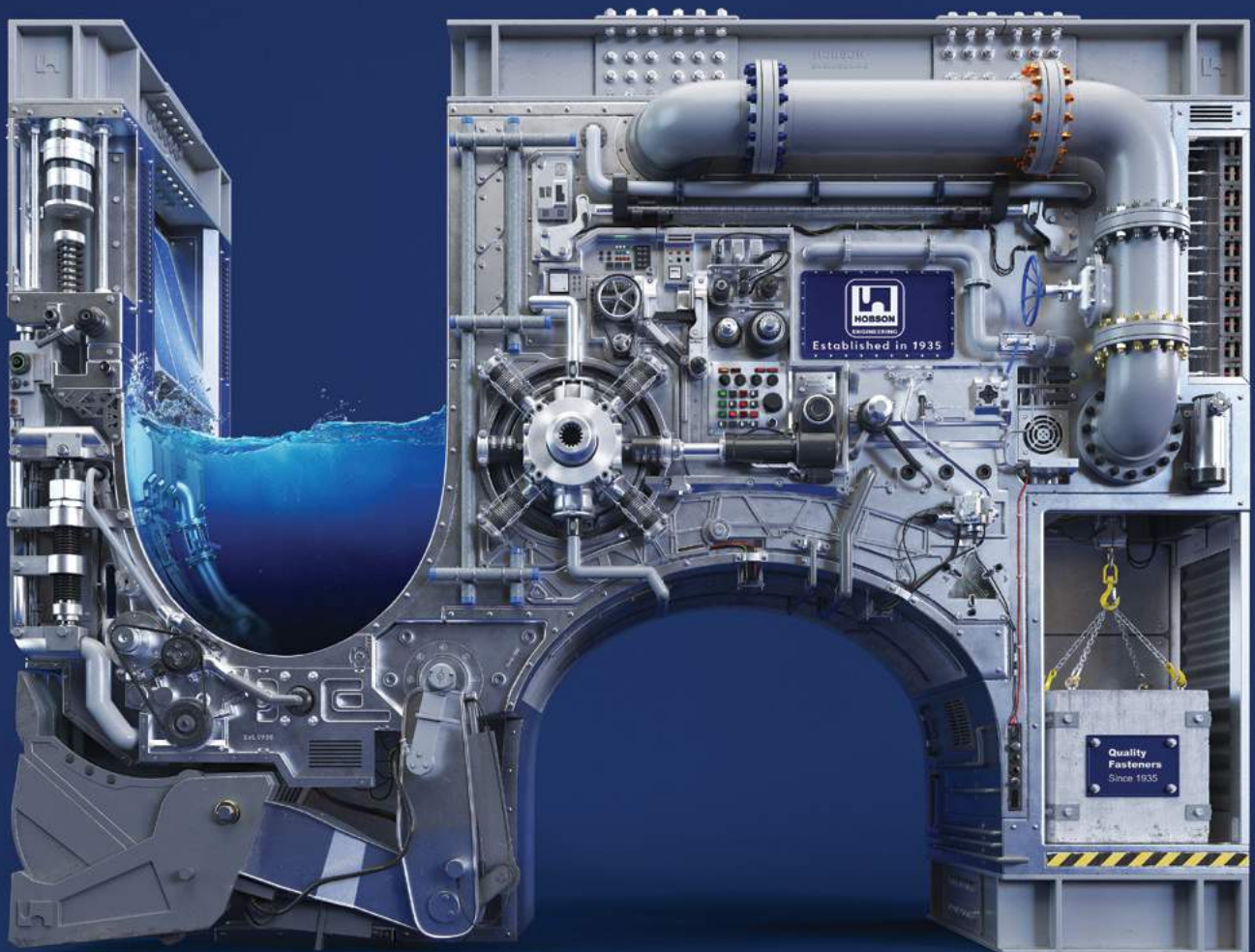

PRODUCT GUIDE

Build **Anything**



Product Types & Categories Chart

Product Types	HIGH-TENSILE	STRUCTURAL	SOKO®	EARTHMOVING	PETROCHEMICAL	STAINLESS HARDWARE	STAINLESS FASTENERS	NEPTUNE®	BUMAX®	NORD-LOCK®	SCHNORR®	WASHERS	NYLON	COMMERCIAL	LOW-TENSILE	MATERIAL HANDLING	MUNGO®	CONXTRACT®	DRILLX®	
Allthread	Hexagon				Hexagon		Hexagon	Hexagon	Hexagon				Hexagon		Hexagon					
Stud Bolts & Nuts					Hexagon		Hexagon													
Bolts	Hexagon	Hexagon	Hexagon	Hexagon	Hexagon		Hexagon	Hexagon	Hexagon				Hexagon	Hexagon						
Nuts	Hexagon	Hexagon	Hexagon	Hexagon	Hexagon		Hexagon	Hexagon	Hexagon	Hexagon			Hexagon	Hexagon	Hexagon					
Washers		Hexagon					Hexagon	Hexagon	Hexagon	Hexagon	Hexagon	Hexagon	Hexagon		Hexagon				Hexagon	Hexagon
Anchors																	Hexagon	Hexagon		
Adhesives																	Hexagon			
Machine Screws							Hexagon						Hexagon	Hexagon						
Socket Screws			Hexagon				Hexagon	Hexagon	Hexagon				Hexagon							
Self-Tapping Screws							Hexagon													Hexagon
Self-Drilling Screws							Hexagon													Hexagon
Security Screws							Hexagon													
Hardware						Hexagon									Hexagon				Hexagon	
Lifting																Hexagon				
Load Restraint																Hexagon				
Bent Bolts	Hexagon					Hexagon									Hexagon		Hexagon			
Rivets																				Hexagon
Pins			Hexagon				Hexagon							Hexagon						
Drive Bits							Hexagon										Hexagon	Hexagon	Hexagon	Hexagon
Drill Bits																	Hexagon		Hexagon	Hexagon
Abrasives & Cutting																	Hexagon			
Foams																	Hexagon			
Tools		Hexagon				Hexagon									Hexagon			Hexagon		

HIGH-TENSILE	4	
STRUCTURAL	12	
SOKO®	24	
EARTHMOVING	30	
PETROCHEMICAL	34	
NORD-LOCK®	40	
SCHNORR®	46	
NEPTUNE®	50	
BUMAX®	54	
TRADE PAX™	58	
STAINLESS HARDWARE	62	
STAINLESS FASTENERS	72	
WASHERS	82	
NYLON	90	
MATERIAL HANDLING	96	
COMMERCIAL	102	
LOW-TENSILE	110	
MUNGO®	118	
CONXTRACT®	132	
DRILLX®	146	
KITS AND MORE	168	

THE

WEST

CO

LISS

THE

WEST

THE

WEST





HIGH-TENSILE















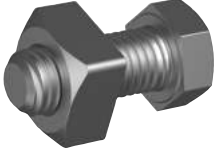

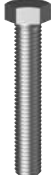
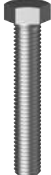
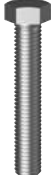







HIGH-TENSILE

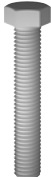

METRIC SAMPSONROD® 1m & 3m						KEY
						PLN PLAIN
AS88GCM	AS88GCM	AS88GFM	AS88PCM	AS88PFM	AS88YCM	Z/P ZINC PLATED (RoHS COMPLIANT)
HDG DIN 975 CLASS 8.8	HDG DIN 975 CLASS 8.8	HDG DIN 975 CLASS 8.8	PLN DIN 975 CLASS 8.8	PLN DIN 975 CLASS 8.8	ZYP DIN 975 CLASS 8.8	ZYP ZINC YELLOW PASSIVATE
						HDG HOT DIP GALVANISED
ASG5GC	ASG5PC	ASG5PF	ASG5PS	ASG5PU	ASG5PW	MGAL MECHANICAL GALVANISED
HDG IFI 136C GRADE 5	PLN IFI 136C GRADE 5	PLN IFI 136C GRADE 5	PLN AS 3501 GRADE 5	PLN IFI 136C GRADE 5	PLN AS 3501 GRADE 5	ZFS ZINC FLAKE SILVER
						D-L LOCK Serrations to LOCK and clamp the connection.
AS10PCM	ASG8PC	AXHC08GCM		BF12FCM		
PLN DIN 975 CLASS 10.9	PLN IFI 136C GRADE 8	HDG HEC CLASS 8		ZFS HEC CLASS 12.9		
BF88ZECM	BF88Y6FM	BF88ZCM	BF10PCM	BF88YCM	BF88YFM	BF88GJNCM
Z/P HEC 1665 CLASS 8.8	ZYP DIN 6921 CLASS 8.8	Z/P DIN 6921 CLASS 8.8	PLN HEC 6921 CLASS 10.9	ZYP JIS B1189 Type 2 CLASS 8.8	ZYP JIS B1189 Type 2 CLASS 8.8	HDG JIS B1189 Type 2 CLASS 8.8



PURLIN HEX 2 WASHER BOLT & NUT  KBHHTGCM HDG HEC CLASS 8.8	PURLIN HEX 2 WASHER BOLT & NUT  KBHHTZCM Z/P HEC CLASS 8.8	PURLIN HEX FLANGE BOLT & NUT  KBFHTGCM HDG HEC CLASS 8.8	PURLIN HEX FLANGE BOLT & NUT  KBFHTZCM Z/P HEC CLASS 8.8	METRIC FASCIA BOLT & NUT  KBIHTGCM HDG HEC CLASS 8.8	TRAILER ADJUSTER BOLT ASSEMBLY  KBS88GQM HDG HEC CLASS 8.8	
HEX BOLT BLANK  BH10PBM PLN AS 1110.1 CLASS 10.9	METRIC HEX SET SCREW  BS88GCM HDG AS 1110.2 CLASS 8.8	METRIC HEX SET SCREW  BS88ZCM Z/P AS 1110.2 CLASS 8.8	METRIC HEX SET SCREW  BS88PCM PLN AS 1110.2 CLASS 8.8	METRIC HEX BOLT  BH88GCM HDG AS 1110.1 CLASS 8.8	METRIC HEX BOLT  BH88PCM PLN AS 1110.1 CLASS 8.8	METRIC HEX BOLT  BH88ZCM Z/P AS 1110.1 CLASS 8.8
METRIC HEX BOLT & NUT  KBH88GCM HDG AS 1110.1 CLASS 8.8	METRIC HEX BOLT & NUT  KBH88ZCM Z/P AS 1110.1 CLASS 8.8	METRIC HEX BOLT & NUT  KBH88PCM PLN AS 1110.1 CLASS 8.8	METRIC FINE HEX SET SCREW  FINE THREAD BS88ZFM Z/P AS1110.2 CLASS 8.8	METRIC FINE HEX SET SCREW  FINE THREAD BS88PFM PLN AS1110.2 CLASS 8.8	METRIC FINE HEX BOLT  FINE THREAD BH88ZFM Z/P AS 1110.1 CLASS 8.8	METRIC FINE HEX BOLT  FINE THREAD BH88PFM PLN AS1110.1 CLASS 8.8
NEW METRIC HEX SET SCREW  BS10ZCM Z/P AS 1110.2 CLASS 10.9	NEW METRIC HEX SET SCREW  BS10PCM PLN AS 1110.2 CLASS 10.9	NEW METRIC HEX SET SCREW  BS10FCM ZFS AS 1110.2 CLASS 10.9	NEW METRIC FINE HEX SET SCREW  FINE THREAD BS10ZFM Z/P AS 1110.2 CLASS 10.9	NEW METRIC FINE HEX SET SCREW  FINE THREAD BS10PFM PLN AS 1110.2 CLASS 10.9	METRIC HEX BOLT  BH10ZCM Z/P AS 1110.1 CLASS 10.9	METRIC HEX BOLT  BH10PCM PLN AS 1110.1 CLASS 10.9



HIGH-TENSILE



METRIC FINE HEX BOLT  BH10ZFM Z/P AS 1110.1 CLASS 10.9	NEW METRIC HEX BOLT  BH10FCM ZFS AS1110.1 CLASS 10.9	NEW METRIC FINE HEX BOLT  BH10PFM PLN AS1110.1 CLASS 10.9	UNC HEX SET SCREW  BSG5ZC Z/P AS 2465 GRADE 5
UNC HEX SET SCREW  BSG5PC PLN AS 2465 GRADE 5	UNC HEX BOLT  BHG5ZC Z/P AS 2465 GRADE 5	UNC HEX BOLT  BHG5PC PLN AS 2465 GRADE 5	UNC HEX BOLT & NUT  KBHG5PC PLN AS 2465 GRADE 5
UNF HEX SET SCREW  BSG5ZF Z/P AS 2465 GRADE 5	UNF HEX SET SCREW  BSG5PF PLN AS 2465 GRADE 5	UNF HEX BOLT  BHG5ZF Z/P AS 2465 GRADE 5	UNF HEX BOLT  BHG5PF PLN AS 2465 GRADE 5
UNC HEX SET SCREW  BSG8ZC Z/P AS 2465 GRADE 8	UNC HEX SET SCREW  BSG8PC PLN AS 2465 GRADE 8	UNC HEX BOLT  BHG8FC ZFS AS 2465 GRADE 8	UNC HEX BOLT  BHG8ZC Z/P AS 2465 GRADE 8

Bolt Terminology

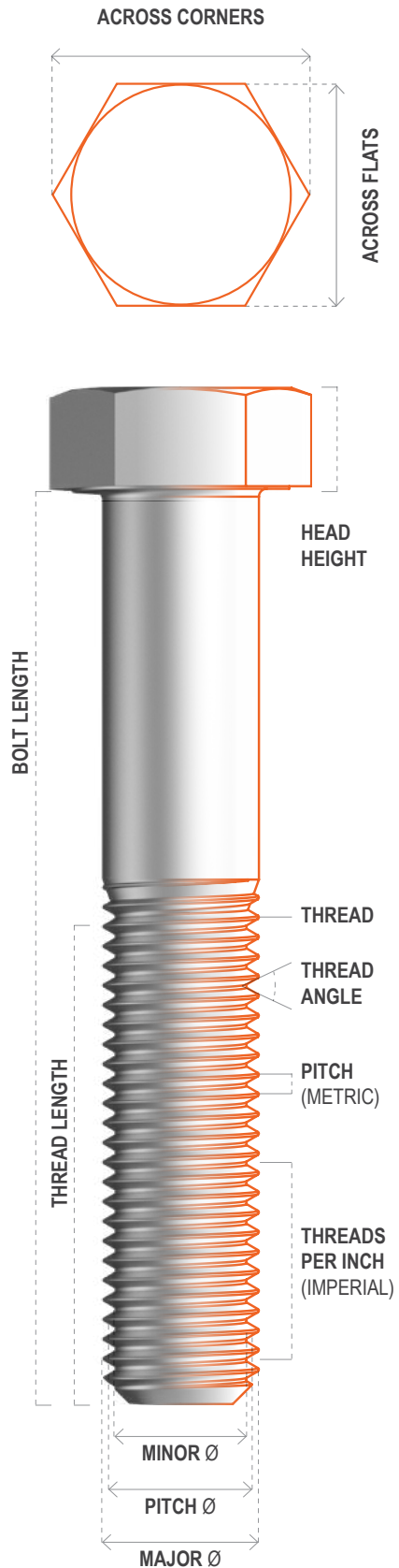



<p>UNC HEX BOLT</p> <p>BHG8PC</p> <p>PLN AS 2465 GRADE 8</p>	<p>UNC HEX BOLT & NUT</p> <p>KBHG8ZC</p> <p>Z/P AS 2465 GRADE 8</p>	<p>UNC HEX BOLT & NUT</p> <p>KBHG8PC</p> <p>PLN AS 2465 GRADE 8</p>	<p>UNF HEX SET SCREW</p> <p>BSG8ZF</p> <p>Z/P AS 2465 GRADE 8</p>	<p>UNF HEX SET SCREW</p> <p>BSG8PF</p> <p>PLN AS 2465 GRADE 8</p>	<p>UNF HEX BOLT</p> <p>BHG8FF</p> <p>ZFS AS 2465 GRADE 8</p>	<p>UNF HEX BOLT</p> <p>BHG8ZF</p> <p>Z/P AS 2465 GRADE 8</p>
<p>UNF HEX BOLT</p> <p>BHG8PF</p> <p>PLN AS 2465 GRADE 8</p>	<p>FISHBOLT & NUT</p> <p>DBD88PCM</p> <p>PLN AS 1085.4 CLASS 8.8</p>	<p>FISHBOLT NUT & SPRING WASHER</p> <p>DBD88PSM</p> <p>PLN AS1085.4/7 CLASS 8.8</p>	<p>NEW METRIC CUP HEAD BOLT & NUT</p> <p>KBC88GCM</p> <p>HDG AS 1390 CLASS 8.8</p>	<p>NEW METRIC CUP HEAD BOLT & NUT</p> <p>KBC10ZCM</p> <p>Z/P AS 1390 CLASS 10.9</p>	<p>NEW UNC CUP HEAD BOLT & NUT</p> <p>KBCG8ZC</p> <p>Z/P ASME B18.5 GRADE 8</p>	<p>NEW SEMS HEX BOLT FLAT WASHER</p> <p>LRBH88ZCM</p> <p>Z/P AS1110.1 CLASS 8.8</p>
<p>NEW HEX FLANGE NUT D-L[®]K</p> <p>SERRATED</p> <p>NF12FCM</p> <p>ZFS HEC CLASS 12</p>	<p>D-L[®]K</p> <p>Serrations to LOCK and clamp the connection.</p>		<p>NEW METRIC HEX FLANGE NUT</p> <p>NO SERRATIONS</p> <p>NF08GJNCM</p> <p>HDG JIS B1190 CLASS 8</p>	<p>NEW METRIC HEX FLANGE NUT</p> <p>SERRATED</p> <p>NF08YJCM</p> <p>ZYP JIS B1190 CLASS 8</p>	<p>NEW METRIC FINE HEX FLANGE NUT</p> <p>SERRATED</p> <p>NF08YJFM</p> <p>ZYP JIS B1190 CLASS 8</p>	<p>METRIC HEX FLANGE NUT</p> <p>SERRATED</p> <p>NF08GCM</p> <p>HDG ISO 4161 CLASS 8</p>
<p>METRIC HEX FLANGE NUT</p> <p>SERRATED</p> <p>NF08ZCM</p> <p>Z/P ISO 4161 CLASS 8</p>	<p>METRIC HEX FLANGE NUT</p> <p>SERRATED</p> <p>NF08YCM</p> <p>ZYP ISO 4161 CLASS 8</p>	<p>METRIC FINE HEX FLANGE NUT</p> <p>SERRATED</p> <p>NF08YFM</p> <p>ZYP ISO 4161 CLASS 8</p>	<p>NEW METRIC HEX FLANGE NUT</p> <p>NO SERRATIONS</p> <p>NF08G6NCM</p> <p>HDG DIN 6923 CLASS 8</p>	<p>NEW METRIC HEX FLANGE NUT</p> <p>NO SERRATIONS</p> <p>NF08Z6NCM</p> <p>Z/P DIN 6923 CLASS 8</p>	<p>METRIC HEX FLANGE NUT</p> <p>SERRATED</p> <p>NF10PCM</p> <p>PLN ISO 4161 CLASS 10</p>	<p>METRIC HEX FLANGE NUT</p> <p>NO SERRATIONS</p> <p>NF10PPM</p> <p>PLN ISO 4161 CLASS 10</p>









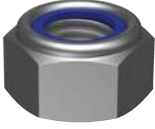
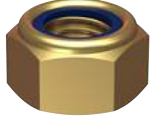

HIGH-TENSILE

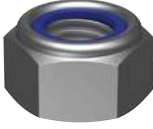
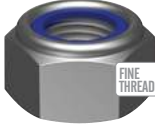
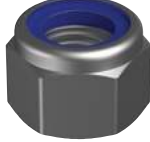
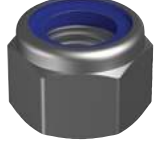
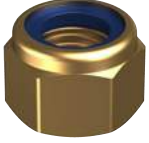
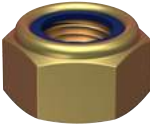
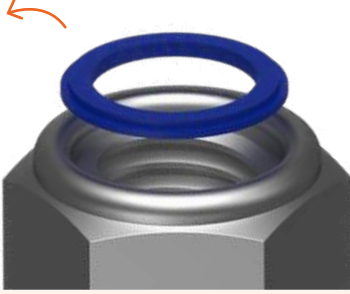
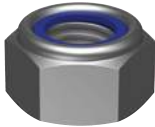
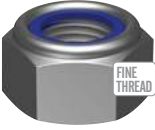
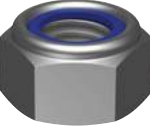
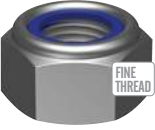
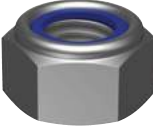
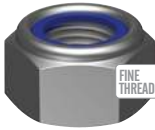
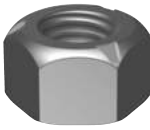

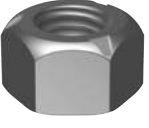
<p>NEW METRIC HEX FLANGE NUT NYLOC</p> <p>NO SERRATIONS</p>  <p>NF08ZNNCM</p> <p>Z/P DIN 6926 CLASS 8</p>	<p>METRIC HEX FLANGE NUT NYLOC</p> <p>NO SERRATIONS</p>  <p>NF10YNM</p> <p>ZYP HEC CLASS 10</p>	<p>UNC HEX FLANGE NUT</p> <p>SERRATED</p>  <p>NFG5YC</p> <p>ZYP IFI 145 / B18 2.2 GRADE 5</p>	<p>UNF HEX FLANGE NUT</p> <p>SERRATED</p>  <p>NFG8PF</p> <p>PLN IFI 145 / B18 2.2 GRADE 8</p>	<p>UNC HEX FLANGE NUT</p> <p>SERRATED</p>  <p>NFG8ZC</p> <p>Z/P IFI 145 / B18 2.2 GRADE 8</p>	<p>UNF HEX FLANGE NUT</p> <p>SERRATED</p>  <p>NFG8ZF</p> <p>Z/P IFI 145 / B18 2.2 GRADE 8</p>	<p>METRIC HEX NUT</p>  <p>NH08GCM</p> <p>HDG AS 1112.1 CLASS 8</p>
<p>METRIC HEX NUT LEFT HAND</p>  <p>NH08GDM</p> <p>HDG AS 1112.1 CLASS 8</p>	<p>METRIC HEX NUT</p>  <p>NH08PCM</p> <p>PLN AS 1112.1 CLASS 8</p>	<p>METRIC FINE HEX NUT</p>  <p>NH08PFM</p> <p>PLN AS 1112.1 CLASS 8</p>	<p>METRIC HEX NUT</p>  <p>NH08ZCM</p> <p>Z/P AS 1112.1 CLASS 8</p>	<p>METRIC FINE HEX NUT</p>  <p>NH08ZFM</p> <p>Z/P AS 1112.1 CLASS 8</p>	<p>NEW METRIC HEX NUT</p>  <p>NH10FCM</p> <p>ZFS A1112.1 CLASS 10</p>	<p>METRIC HEX NUT</p>  <p>NH10PCM</p> <p>PLN AS 1112.1 CLASS 10</p>
<p>METRIC FINE HEX NUT</p>  <p>NH10PFM</p> <p>PLN AS 1112.1 CLASS 10</p>	<p>METRIC HEX NUT</p>  <p>NH10ZCM</p> <p>Z/P AS 1112.1 CLASS 10</p>	<p>METRIC FINE HEX NUT</p>  <p>NH10ZFM</p> <p>Z/P AS 1112.1 CLASS 10</p>	<p>UNC HEX NUT</p>  <p>NHG5PC</p> <p>PLN AS 2465 GRADE 5</p>	<p>UNF HEX NUT</p>  <p>NHG5PF</p> <p>PLN AS 2465 GRADE 5</p>	<p>UNC HEX NUT</p>  <p>NHG5ZC</p> <p>Z/P AS 2465 GRADE 5</p>	<p>UNF HEX NUT</p>  <p>NHG5ZF</p> <p>Z/P AS 2465 GRADE 5</p>
<p>UNC HEX NUT</p>  <p>NHG8FC</p> <p>ZFS AS 2465 GRADE 8</p>	<p>UNC HEX NUT</p>  <p>NHG8PC</p> <p>PLN AS 2465 GRADE 8</p>	<p>UNF HEX NUT</p>  <p>NHG8PF</p> <p>PLN AS 2465 GRADE 8</p>	<p>UNC HEX NUT</p>  <p>NHG8ZC</p> <p>Z/P AS 2465 GRADE 8</p>	<p>UNF HEX NUT</p>  <p>NHG8ZF</p> <p>Z/P AS 2465 GRADE 8</p>	<p>METRIC THIN HEX LOCK NUT</p>  <p>NL08GCM</p> <p>HDG AS1112.4 USE WITH CLASS 8</p>	<p>METRIC THIN HEX LOCK NUT</p>  <p>NL08ZCM</p> <p>Z/P AS1112.4 USE WITH CLASS 8</p>

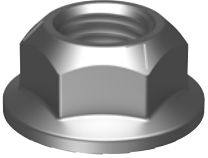
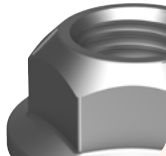

<p>METRIC HEX NUT NYLOC</p>  <p>NN08GCM</p> <p>MGAL DIN 985 CLASS 8</p>	<p>METRIC HEX NUT NYLOC</p>  <p>NN08YCM</p> <p>ZYP DIN 985 CLASS 8</p>	<p>METRIC FINE HEX NUT NYLOC</p>  <p>NN08YFM</p> <p>ZYP DIN 985 CLASS 8</p>	<p>METRIC HEX NUT NYLOC</p>  <p>NN08ZCM</p> <p>Z/P DIN 985 CLASS 8</p>	<p>METRIC FINE HEX NUT NYLOC</p>  <p>NN08ZFM</p> <p>Z/P DIN 985 CLASS 8</p>	<p>METRIC HEAVY NUT NYLOC</p>  <p>NN08ZHCM</p> <p>Z/P DIN 982 CLASS 8</p>	<p>METRIC HEAVY NUT NYLOC</p>  <p>NN10ZHCM</p> <p>Z/P DIN 982 CLASS 10</p>
<p>METRIC HEAVY NUT NYLOC</p>  <p>NN08Y6CM</p> <p>ZYP DIN 6924 CLASS 8</p>	<p>METRIC HEX NUT NYLOC</p>  <p>NN10YCM</p> <p>ZYP DIN 985 CLASS 10</p>	<p>NYLOC®</p> <p>The special nylon insert prevents loosening caused by vibration.</p> 			<p>METRIC HEX NUT NYLOC</p>  <p>NN10ZCM</p> <p>Z/P DIN 985 CLASS 10</p>	
<p>METRIC FINE NUT NYLOC</p>  <p>NN10ZFM</p> <p>Z/P DIN 985 CLASS 10</p>	<p>UNC HEX NUT NYLOC</p>  <p>NNG5Z</p> <p>Z/P IFI-100 NE GRADE 5</p>	<p>UNF HEX NUT NYLOC</p>  <p>NNG5ZF</p> <p>Z/P IFI-100 NE GRADE 5</p>	<p>UNC HEX NUT NYLOC</p>  <p>NNG8ZC</p> <p>Z/P IFI-100 NE GRADE 8</p>	<p>UNF HEX NUT NYLOC</p>  <p>NNG8ZF</p> <p>Z/P IFI-100 NE GRADE 8</p>	<p>METRIC CONE LOCK HCL NUT</p>  <p>NC10ZCM</p> <p>Z/P DIN 980 CLASS 10</p>	<p>METRIC FINE CONE LOCK HCL NUT</p>  <p>NC10ZFM</p> <p>Z/P DIN 980 CLASS 10</p>
<p>UNC CONE LOCK HCL NUT</p>  <p>NCGCZ</p> <p>Z/P IFI 100-107 GRADE C</p>	<p>UNF CONE LOCK HCL NUT</p>  <p>NCGCZF</p> <p>Z/P IFI 100-107 GRADE C</p>	<p>NEW HEX FLANGED CONE LOCK NUT</p> <p>SERRATED</p>  <p>NF10Z7SCM</p> <p>Z/P DIN 6927 CLASS 10</p>			<p>Cone Lock</p> <p>Cone lock protects against loosening by adding prevailing torque to the connection.</p> 	<p>STARTER BAR L BOLT</p>  <p>LB88ZCM</p> <p>Z/P HEC CLASS 8.8</p>

STUBS STUBS





STRUCTURAL



STRUCTURAL



AS/NZS 1252: 2016 K0 8.8 HR

KO Structural Assembly

Setting the standard in structural bolting



PRODUCT





LABEL

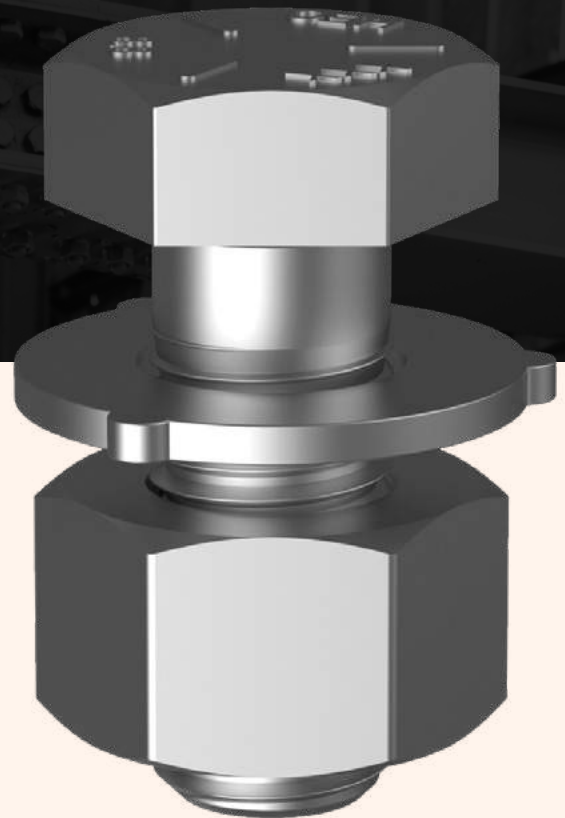

DOCUMENTATION

K0 RANGE COMPLIES WITH AS/NZS 1252

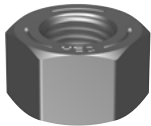
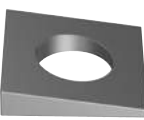
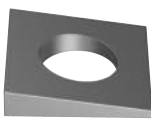

<p>K0 STRUCTURAL ASSEMBLY</p>  <p>KBHK0GCM</p> <p>HDG AS1252:2016 K0 CLASS 8.8</p>	<p>K0 STRUCTURAL WASHER</p>  <p>WRK0GM</p> <p>HDG AS1252:2016 K0 35-41 HRC</p>	<p>K0 STRUCTURAL WASHER</p>  <p>WRK0PM</p> <p>PLN AS1252:2016 K0 35-41 HRC</p>	
<p>K0 STRUCTURAL NUT</p>  <p>NHK0GCM</p> <p>HDG AS1252:2016 K0 CLASS 8</p>	<p>K0 STRUCTURAL NUT</p>  <p>NHK0PCM</p> <p>PLN AS1252:2016 K0 CLASS 8</p>	<p>K0 TAPER WASHER 8° SQUARE</p>  <p>WTK0GM</p> <p>HDG AS1252:2016 K0 33-41 HRC</p>	<p>K0 TAPER WASHER 8° SQUARE</p>  <p>WTK0PM</p> <p>PLN AS1252:2016 K0 33-41 HRC</p>



Unique 3-character trace code on the bolt head.

FULL TRACEABILITY

AL3 

hobson.com.au



EN 14399-3 K2 8.8 HR

K2

Structural Assembly

Setting the standard in structural bolting



PRODUCT



LABEL



DOCUMENTATION

K2 RANGE COMPLIES WITH EN 14399

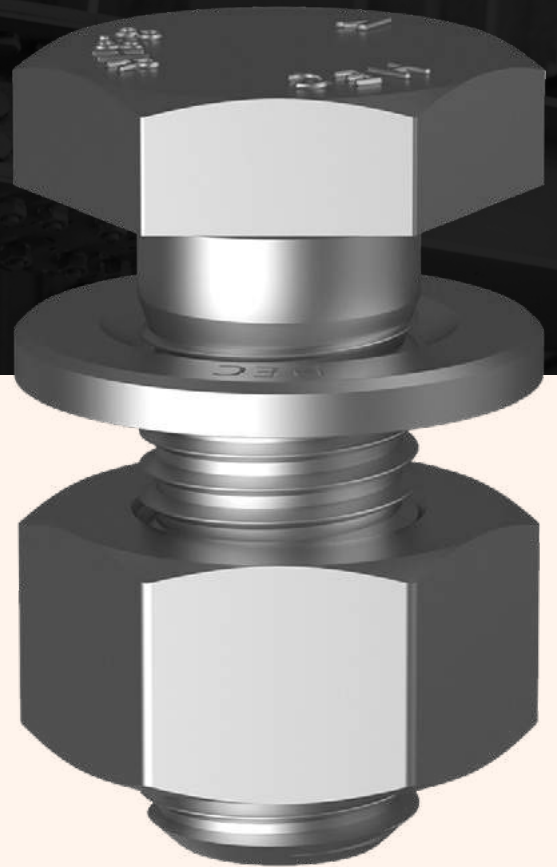

**K2
STRUCTURAL
ASSEMBLY**



KBHK2GCM

HDG
EN14399-3 K2
CLASS 8.8

**NEW K2
STRUCTURAL
ASSEMBLY**



KBHK9GCM

HDG
EN14399-3 K2
CLASS 10.9

**NEW K2
STRUCTURAL
ASSEMBLY**



KBHK9PCM

PLN
EN14399-3 K2
CLASS 10.9

**K2
STRUCTURAL
WASHER**



WRK2GM

HDG
EN14399-5 K2
32-45 HRC

**NEW K2
STRUCTURAL
NUT**

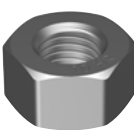

NHK9GCM

HDG
EN14399 K2
CLASS 10



Unique
3-character
trace code on
the bolt head.



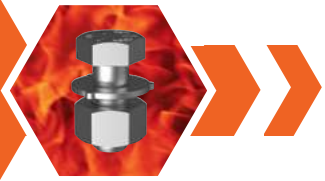

STRUCTURAL



ASTM A325M TYPE 3 8.8

Structural Assembly

For enhanced weather resistance



**NEW
STRUCTURAL
ASSEMBLY**



KBH83WCM
WSTL
ASTM A325M-3
CLASS 8.8



Unique 3-character trace code on the bolt head.

FULL TRACEABILITY

AN7 

hobson.com.au

Weathering Steel







NEW



5+ years

PATINA forms and matures on the top layer when subjected to alternating wet and dry conditions.

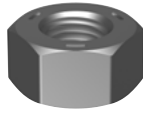
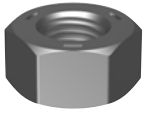
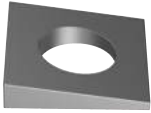
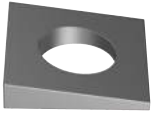
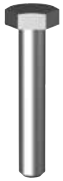

STRUCTURAL ASSEMBLY	STRUCTURAL WASHER	STRUCTURAL WASHER	STRUCTURAL HEX NUT	STRUCTURAL HEX NUT	TAPER WASHER 8° SQUARE	KEY
						PLN PLAIN
KBHSTGCM	WRSTGM	WRSTPM	NHSTGCM	NHSTPCM	WTSTGM	Z/P ZINC PLATED (RoHS COMPLIANT)
HDG AS1252:1983 CLASS 8.8	HDG AS1252:1983 26-45 HRC	PLN AS1252:1983 35-45 HRC	HDG AS1252:1983 CLASS 8	PLN AS1252:1983 CLASS 8	HDG AS1252:1983 26-45 HRC	ZYP ZINC YELLOW PASSIVATE
TAPER WASHER 8° SQUARE	STRUCTURAL BOLT BLANK	FEELER GAUGE	STICK WAX LUBRICANT			HDG HOT DIP GALVANISED
						MGAL MECHANICAL GALVANISED
WTSTPM	BHSTPBM	XGF013	XXWSC			ZFS ZINC FLAKE SILVER
PLN AS1252:1983 35-45 HRC	PLN AS1252:1983 CLASS 8.8	301 STAINLESS 0.13MM	CARTRIDGE 425G FOR BOLTS / NUTS			WSTL WEATHERING STEEL

Accreditation, Certification and Memberships



CERTIFICATION



ACCREDITATION



MEMBERSHIP



MEMBERSHIP - Founding Member



ASTM F959 DIRECT TENSION INDICATOR



DTI Washers

Make bolting simple

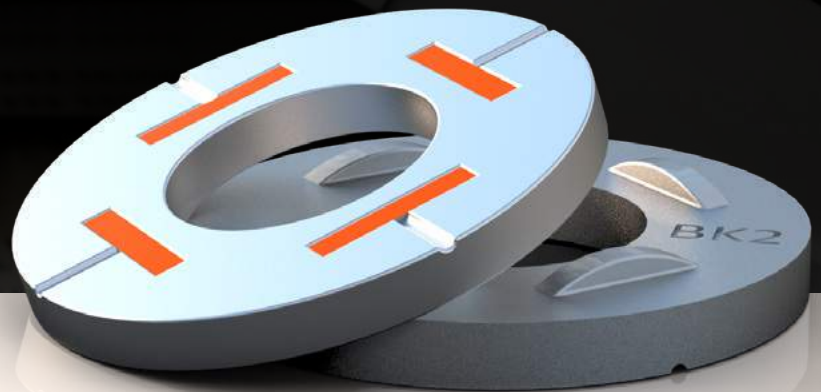

Visual confirmation of the bolt tension.

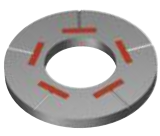
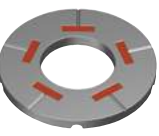
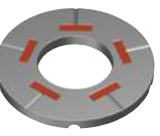
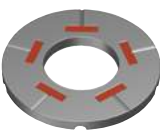
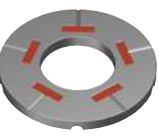

<p>NEW METRIC DURASQUIRT® DTI WASHER</p>  <p>WDSTDGM</p> <p>MGAL ASTM F959M CLASS 8.8</p>	<p>METRIC SQUIRTER DTI WASHER</p>  <p>WDSTGM</p> <p>MGAL ASTM F959M CLASS 8.8</p>	<p>METRIC SQUIRTER DTI WASHER</p>  <p>WD10MM</p> <p>MGAL ASTM F959M CLASS 10.9</p>
<p>METRIC SQUIRTER DTI WASHER</p>  <p>WD10PM</p> <p>PLN ASTM F959M CLASS 10.9</p>	<p>SQUIRTER DTI WASHER</p>  <p>WDSTG</p> <p>MGAL ASTM F959 GRADE 5</p>	<p>METRIC LOAD INDICATOR WASHER</p>  <p>WISTGM</p> <p>MGAL ASTM F959M CLASS 8.8</p>

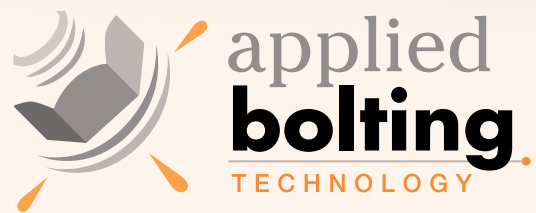

Unique 3-character trace code on the bolt head.



CLASS 8.8 - BLIND & HOLLOW STEEL CONNECTIONS

HBS-BOLT®

One-sided installation

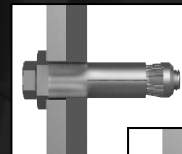
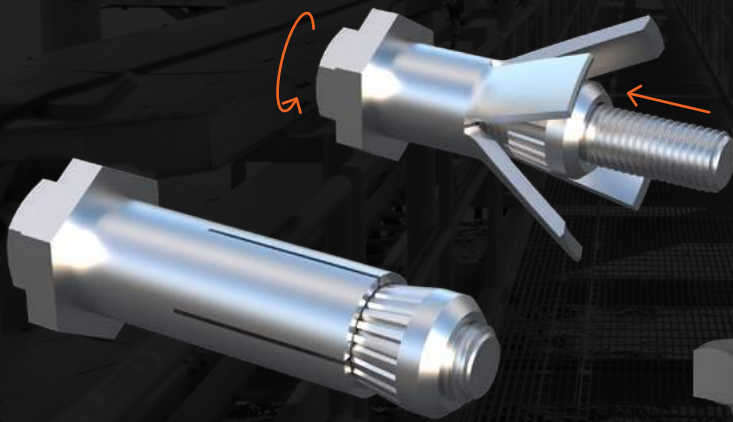

Blind & hollow installation

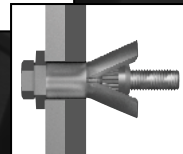

NEW HEX HBS-BOLT®



KBB88GHM

HDG
CLASS 8.8

NEW CSK HBS-BOLT®



KBB88GKM

HDG
CLASS 8.8



3-PART ASSEMBLY

M8 | M10 | M12



5-PART ASSEMBLY

M16 | M20



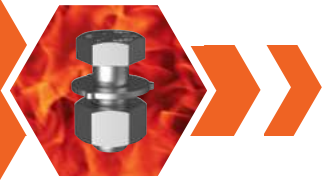

STRUCTURAL



EN 14399-10 10.9 K0 HRC

TCBOLT

Safe, easy and accurate

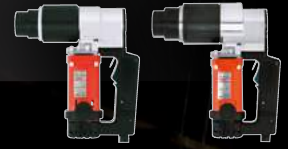

Use with
TONE® TCBOLT
Shear Wrenches

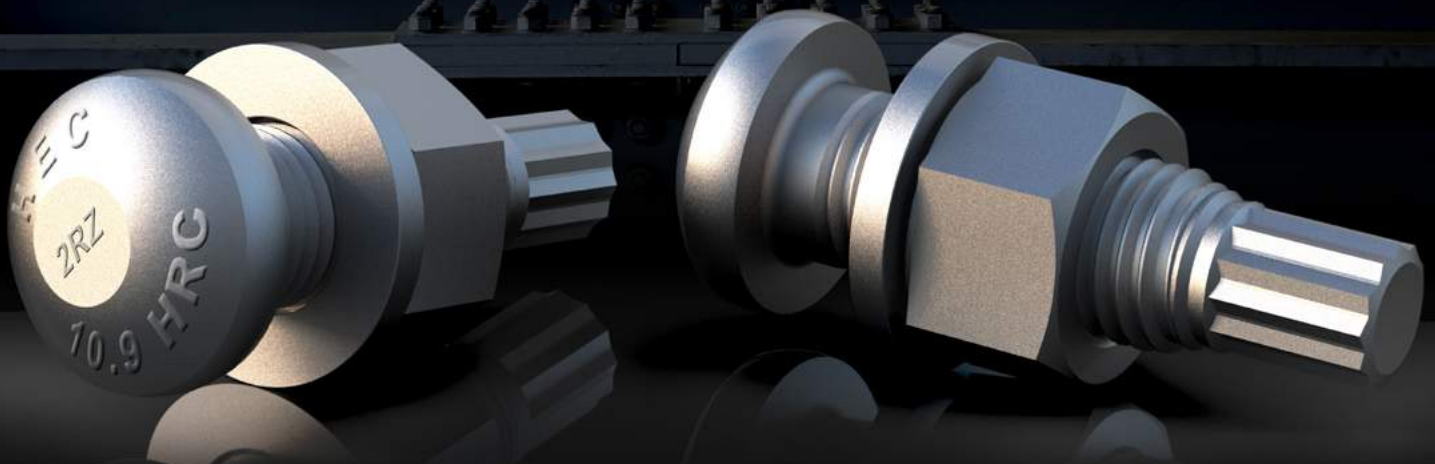

**NEW K0
TCBOLT**



KBCT9GCM

HDG
EN14399-10:2018
CLASS 10.9

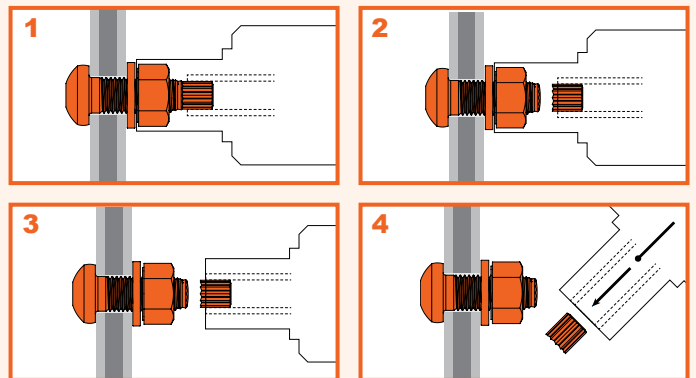
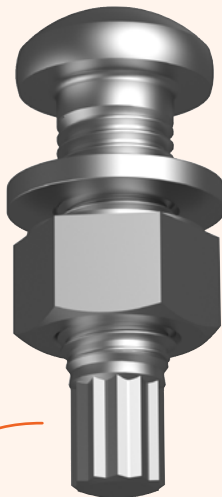

The Spline

TCBOLTS are installed with
**TONE® TCBOLT Shear
Wrenches**

When the correct pre-load is reached, the outer socket stops rotating. The inner socket then counter-rotates and shears the spline off before the wrench safely ejects the spline. The bolt is now properly installed with the correct tension.



Unique
3-character
trace code on
the bolt head

**FULL
TRACEABILITY**

2RZ 

hobson.com.au



TONE®



Japanese Engineering



- Strong and long-lasting
- Low counter-force reduces burden to users
- Anti-defacement mechanism & tip ejector installed

NEW TONE TCBOLT SHEAR WRENCH



TONE

XT-GM-222EZ

WITH M20 INN / OUT SOCKETS
TORQUE RANGE M16-M22
MAX TORQUE 735NM

NEW TONE TCBOLT SHEAR WRENCH



TONE

XT-GH-242EZ

WITH M24 INN / OUT SOCKETS
TORQUE RANGE M16-M24
MAX TORQUE 950NM

NEW TONE ELECTRIC TORQUE WRENCH



TONE

XT-STC30TE

TORQUE RANGE 1000NM ~ 3000NM
MAX TORQUE 3000NM

TONE TORQUE WRENCH



TONE

XT-STC12TE

REACTION ARM
1 INCH SQ TORQUE
RANGE 500-1200NM

NEW TCBOLT GM INNER SOCKET



TONE

XT-GM-SI

BLACK
GM SERIES
M16-M22

NEW TCBOLT GM OUTER SOCKET



TONE

XT-GM-SO

BLACK
GM SERIES
M16-M22

NEW TCBOLT GH INNER SOCKET



TONE

XT-GH-SI

BLACK
GH SERIES
M16-M24

NEW TCBOLT GH OUTER SOCKET



TONE

XT-GH-SO

BLACK
GH SERIES
M16-M24

NEW TONE ELECTRIC TORQUE WRENCH



TONE

XT-STC50TE

TORQUE RANGE 2000NM ~ 5000NM
MAX TORQUE 5000NM

TONE TORQUE WRENCH



TONE

XT-STC7TE

REACTION ARM
1 INCH SQ TORQUE
RANGE 350-700NM



Structural Bolting

Tension methods



	PART-TURN METHOD	SQUIRTER DTI METHOD	TCBOLT METHOD
TENSION INDICATION (INSPECTION)	ROTATION OF NUT RELATIVE TO BOLT	COMPRESSION OF BUMPS, SQUIRT MEDIUM	SPLINE END SHEARED OFF
INSTALLATION TIME	⌚ ⌚ ⌚ ⌚	≡ ⌚ ⌚	≡ ⌚
INSTALLERS NEEDED	👤 👤	👤 👤	👤
ENSURES MINIMUM TENSION	✘	✔	✔

Experience has shown that on medium to large projects the extra cost of DTI washers and TCBOLTS methods is offset by major savings in installation, supervision, and inspection of high-strength joints.



Quality Assurance **Documentation** Online

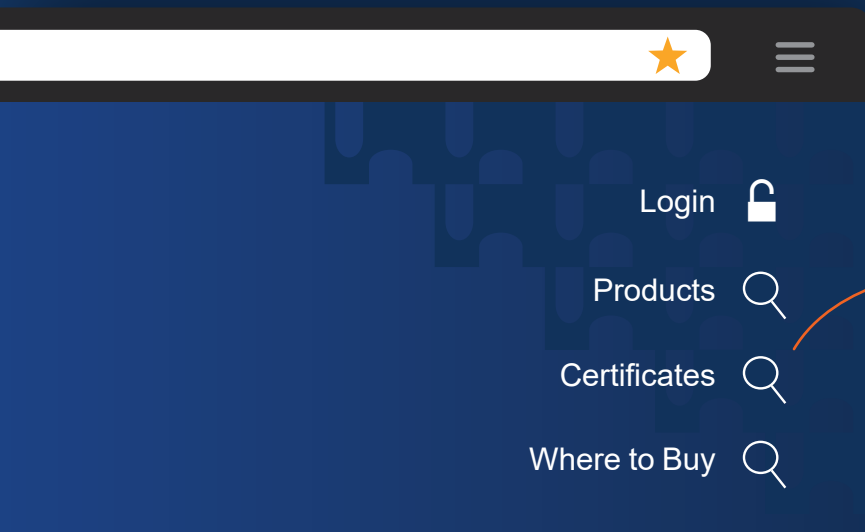
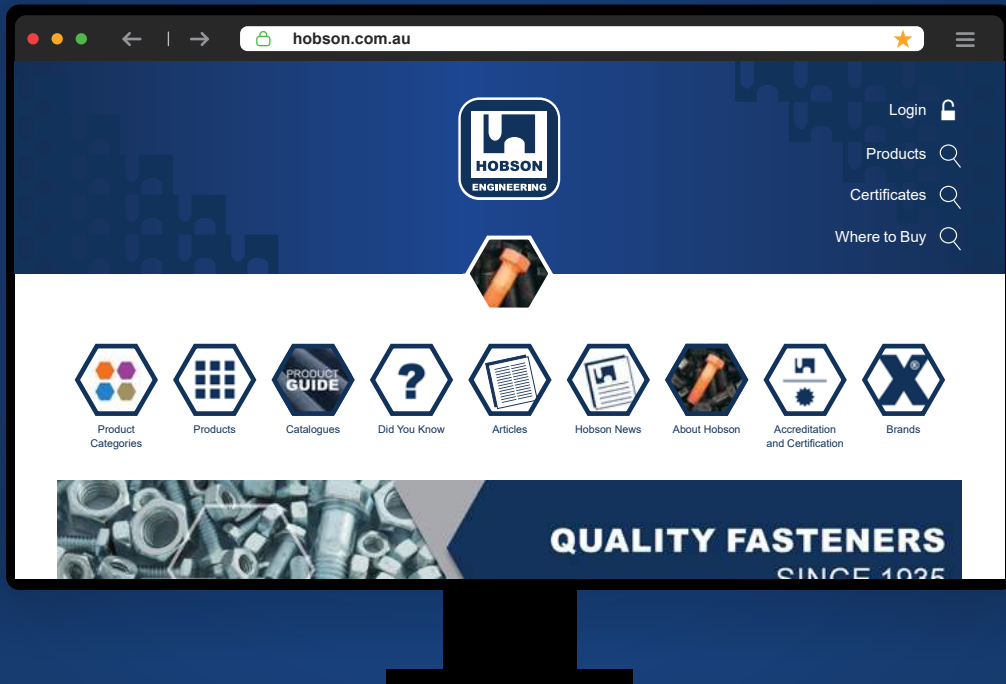

Go to **hobson.com.au** and click on **Certificates** to find the relevant documentation.

Type the unique 3-character Trace Code on the bolt head, or the Trace Number on the label.



CO M S















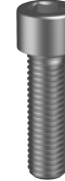











SOKO®



SOKO

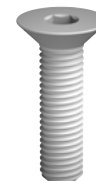

METRIC CAP SCREW SOCKET	UNC CAP SCREW SOCKET	METRIC FINE CAP SCREW SOCKET	METRIC CAP SCREW SOCKET	NEW METRIC CAP SCREW SOCKET	NEW UNC CAP SCREW SOCKET	KEY
 <p>SHSOZCM</p> <p>Z/P DIN 912 CLASS 12.9</p>	 <p>SHSOZC</p> <p>Z/P ANSI B18.3 ASTM A574</p>	 <p>SHSOZFM</p> <p>Z/P DIN 912 CLASS 12.9</p>	 <p>SHSOPCM</p> <p>PLN DIN 912 CLASS 12.9</p>	 <p>SHSOFCM</p> <p>ZFS DIN 912 CLASS 12.9</p>	 <p>SHSOFC</p> <p>ZFS ANSI B18.3 ASTM A574</p>	<p>PLN PLAIN</p> <p>Z/P ZINC PLATED (RoHS COMPLIANT)</p> <p>ZYP ZINC YELLOW PASSIVATE</p> <p>HDG HOT DIP GALVANISED</p> <p>MGAL MECHANICAL GALVANISED</p> <p>ZFS ZINC FLAKE SILVER</p> <p>ALLOY ALLOY STEEL</p>
 <p>SHSOFFM</p> <p>ZFS DIN 912 CLASS 12.9</p>	 <p>SH88ZCM</p> <p>Z/P DIN 912 CLASS 8.8</p>	 <p>SHSOP</p> <p>PLN ANSI B18.3 ASTM A574</p>	 <p>SHSOPW</p> <p>PLN BS 2470 ASTM A574</p>			
 <p>SHSOPFM</p> <p>PLN DIN 912 CLASS 12.9</p>	 <p>SHSOFF</p> <p>ZFS ANSI B18.3 ASTM A574</p>	 <p>SHSOPF</p> <p>PLN ANSI B18.3 ASTM A574</p>	 <p>SLSOPCM</p> <p>PLN DIN 7984 CLASS 010.9</p>	 <p>SLSOP</p> <p>PLN ANSI B18.3 ALLOY STEEL</p>	 <p>SLSOFCM</p> <p>ZFS DIN 7984 CLASS 010.9</p>	 <p>SCSOZC</p> <p>Z/P ANSI B18.3 ASTM F835</p>
 <p>SCSOP</p> <p>PLN ANSI B18.3 ASTM F835</p>	 <p>SCSOPC</p> <p>PLN ANSI B18.3 ASTM F835</p>	 <p>SCSOPW</p> <p>PLN BS 2470 ASTM F835</p>	 <p>SCSOPF</p> <p>PLN ANSI B18.3 ASTM F835</p>	 <p>SC10ZCM</p> <p>Z/P DIN 7991 CLASS 010.9</p>	 <p>SC10PCM</p> <p>PLN DIN 7991 CLASS 010.9</p>	 <p>SCSOFCM</p> <p>ZFS DIN 7991 CLASS 012.9</p>



<p>METRIC CSK FLAT SOCKET</p>  <p>SCSOZCM</p> <p>Z/P DIN 7991 CLASS 012.9</p>	<p>METRIC CSK FLAT SOCKET</p>  <p>SCSOPCM</p> <p>PLN DIN 7991 CLASS 012.9</p>	<p>METRIC BUTTON HEAD SOCKET</p>  <p>SBSOZCM</p> <p>Z/P ISO 7380 CLASS 012.9</p>	<p>METRIC BUTTON HEAD SOCKET</p>  <p>SBSOPCM</p> <p>PLN ISO 7380 CLASS 012.9</p>	<p>UNC BUTTON HEAD SOCKET</p>  <p>SBSOZC</p> <p>Z/P ANSI B18.3 ASTM F835</p>	<p>UNC BUTTON HEAD SOCKET</p>  <p>SBSOP</p> <p>PLN ANSI B18.3 ASTM F835</p>	<p>UNF BUTTON HEAD SOCKET</p>  <p>SBSOPF</p> <p>PLN ANSI B18.3 ASTM F835</p>
<p>NEW METRIC BUTTON HEAD SOCKET</p>  <p>SBSOFCM</p> <p>ZFS ISO 7380 CLASS 012.9</p>	<p>BSW BUTTON HEAD SOCKET</p>  <p>SBSOPW</p> <p>PLN BS 2470 ALLOY STEEL</p>	<p>METRIC BUTTON HEAD SOCKET</p>  <p>SB10ZCM</p> <p>Z/P ISO 7380 CLASS 010.9</p>	<p>NEW METRIC BUTTON HEAD SOCKET</p>  <p>SB10PCM</p> <p>PLN ISO 7380 CLASS 010.9</p>	<p>METRIC BUTTON HEAD SOCKET</p>  <p>SB88ZCM</p> <p>Z/P ISO 7380 CLASS 08.8</p>	<p>METRIC PLAIN PNT SOCKET</p>  <p>SSSPPCM</p> <p>PLN ISO 4029 ALLOY STEEL</p>	<p>METRIC KNURL CUP PNT SOCKET</p>  <p>SSSKZCM</p> <p>Z/P ISO 4029 ALLOY STEEL</p>
<p>METRIC KNURL CUP PNT SOCKET</p>  <p>SSSKPCM</p> <p>PLN ISO 4029 ALLOY STEEL</p>	<p>NEW UNC KNURL CUP PNT SOCKET</p>  <p>SSSKFCM</p> <p>ZFS ISO 4029 ALLOY STEEL</p>	<p>METRIC DOG PNT SOCKET</p>  <p>SSSDPCM</p> <p>PLN DIN 915 ALLOY STEEL</p>	<p>UNC PLAIN PNT SOCKET</p>  <p>SSSPPC</p> <p>PLN ANSI B18.3 ASTM F912</p>	<p>UNC KNURL CUP PNT SOCKET</p>  <p>SSSKP</p> <p>PLN ANSI B18.3 ASTM F912</p>	<p>UNC KNURL CUP PNT SOCKET</p>  <p>SSSKPC</p> <p>PLN ANSI B18.3 ASTM F912</p>	<p>BSW KNURL CUP PNT SOCKET</p>  <p>SSSKPW</p> <p>PLN BS 2470 ALLOY STEEL</p>
<p>UNF KNURL CUP PNT SOCKET</p>  <p>SSSKPF</p> <p>PLN ANSI B18.3 ASTM F912</p>	<p>UNF PLAIN PNT SOCKET</p>  <p>SSSPPF</p> <p>PLN ANSI B18.3 ASTM F912</p>	<p>UNC SHOULDER SOCKET</p>  <p>SOSOPC</p> <p>PLN ANSI B18.3 ALLOY STEEL</p>	<p>METRIC SHOULDER SOCKET</p>  <p>SOSOPCM</p> <p>PLN ISO 7379 CLASS 012.9</p>	<p>BSW SHOULDER SOCKET</p>  <p>SOSOPW</p> <p>PLN BS 2470 ALLOY STEEL</p>	<p>METRIC HEX NUT</p>  <p>NH12PCM</p> <p>PLN AS1112.1 CLASS 12</p>	



METRIC T-BOLT



BTSOPCM

PLN
HEC
CLASS 10.9

BSW T-BOLT



BTSOPW

PLN
HEC
CLASS 10.9

BSP PRESSURE PLUG HEX



PPSOPB

PLN
ALLOY STEEL

Dowel Pin



CHAMFERED ENDS
for easy insertion into
pre-drilled hole.

NEW DOWEL PIN



PDSOPM

PLN
DIN 6325 M6
ALLOY STEEL

S-LOK SPRING PIN



PLSOZ

Z/P
HEC

NEW S-LOK SPRING PIN



QPLSOB

BLACK OXIDE
ISO 8752

Marking symbols for fasteners with **reduced loadability**



Fasteners with reduced loadability possess material properties according to the appropriate standard. However, geometry inhibits them from achieving full tensile capacity.



Countersunk (Flat), Buttonhead and Low Head Socket cap screw have reduced loadability as the stress area in the head is smaller than that in the threads.

The head markings of fasteners with reduced loadability are prefixed with a '0'.

Property Class	8.8	10.9	12.9
Marking	08.8	010.9	012.9



Find more **Articles** online

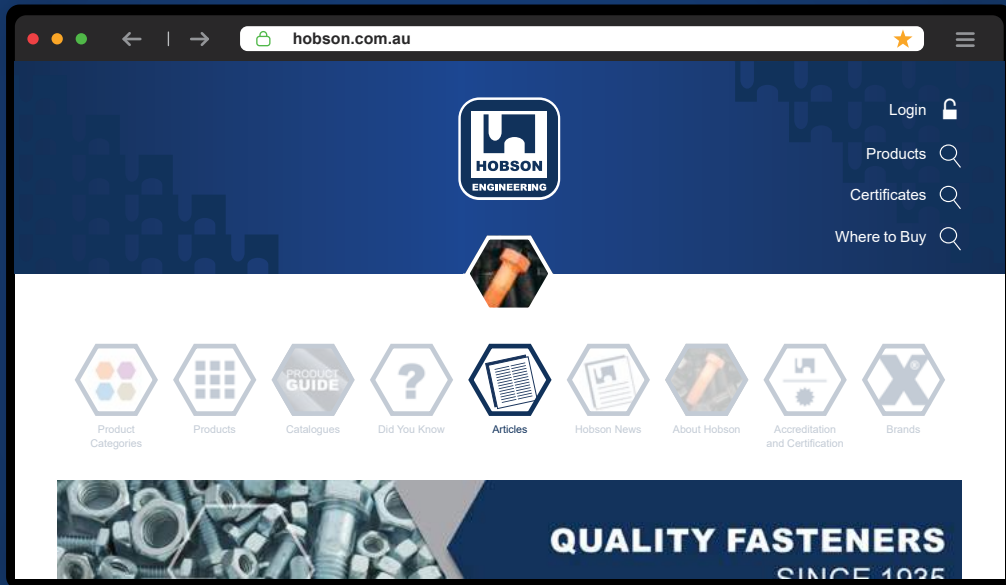

Look for the **Articles** icon on the main menu to find updates, research, engineering information and more.



Articles

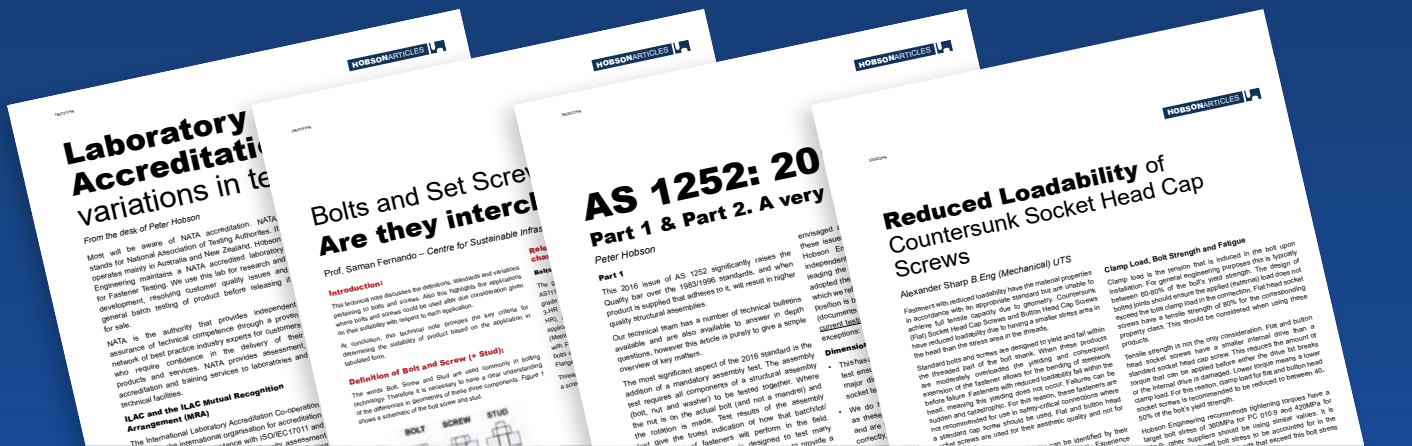

EARLY TRAINING





EARTHMOVING



GRADE 8 AND 9

PLOW BOLTS & NUTS

**UNC
PLOW BOLT**



CBPG9PC

PLN
GRADE 9

**UNC
PLOW BOLT**



CBPG8PC

PLN
GRADE 8

Securing the cutting edges of earthmoving blades.

**UNC
PLOW BOLT
RAISED HEAD
STEPPED**



CBXG9PC

PLN
GRADE 9

**UNC
PLOW BOLT
LONG SHOULDER**



CBLG9PC

PLN
GRADE 9

**UNC
HEX
PLOW NUT**



CNPG8PC

PLN
GRADE 8

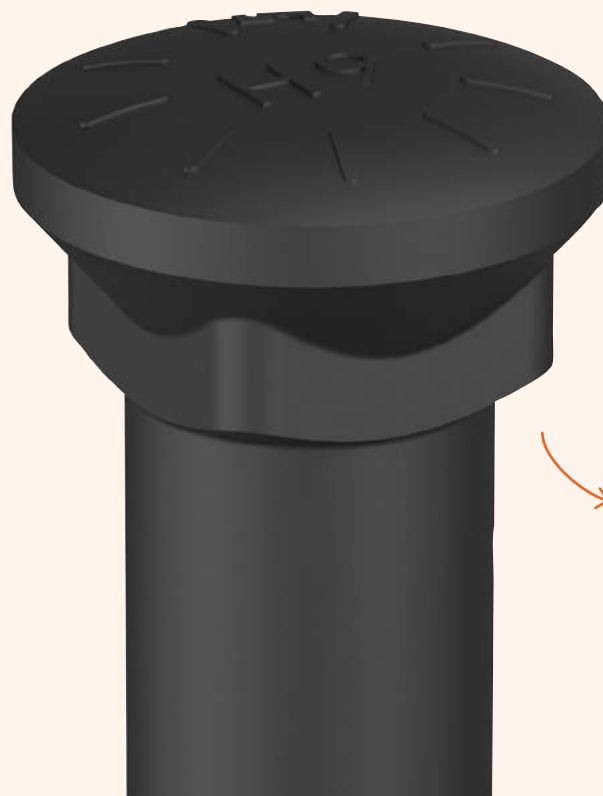

Cold forged square neck and raised head for greater strength.



GRADE 8 AND 9

TRACK BOLTS & NUTS

**METRIC FINE
DOME HEX
TRACK BOLT**



CBTG9DFM

PLN
GRADE 9

**UNF
DOME HEX
TRACK BOLT**



CBTG9DF

PLN
GRADE 9

Made from high grade alloy steel for increased toughness.

**METRIC FINE
HEX
TRACK BOLT**



CBTG9HFM

PLN
GRADE 9

**UNF
HEX
TRACK BOLT**



CBTG9HF

PLN
GRADE 9

**METRIC FINE
SQUARE COLLAR
TRACK NUT**

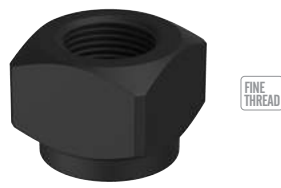

CNTG8CFM

PLN
GRADE 8

**UNF HEX
RND FACE
TRACK NUT**

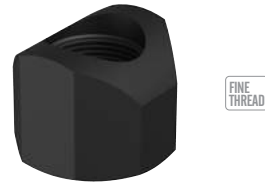

CNTG8EF

PLN
GRADE 8

**UNC
HEX
TRACK NUT**



CNTG8HF

PLN
GRADE 8

**UNF SQUARE
RND FACE
TRACK NUT**



CNTG8RF

PLN
GRADE 8

**METRIC FINE
RND FACE
TRACK NUT**



CNTG8RFM

PLN
GRADE 8

**UNF
SQUARE
TRACK NUT**

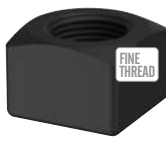

CNTG8QF

PLN
GRADE 8

**METRIC FINE
SQUARE
TRACK NUT**



CNTG8QFM

PLN
GRADE 8

**UNF SQUARE
STEPPED
TRACK NUT**



CNTG8SF

PLN
GRADE 8

PRETTIFICAL

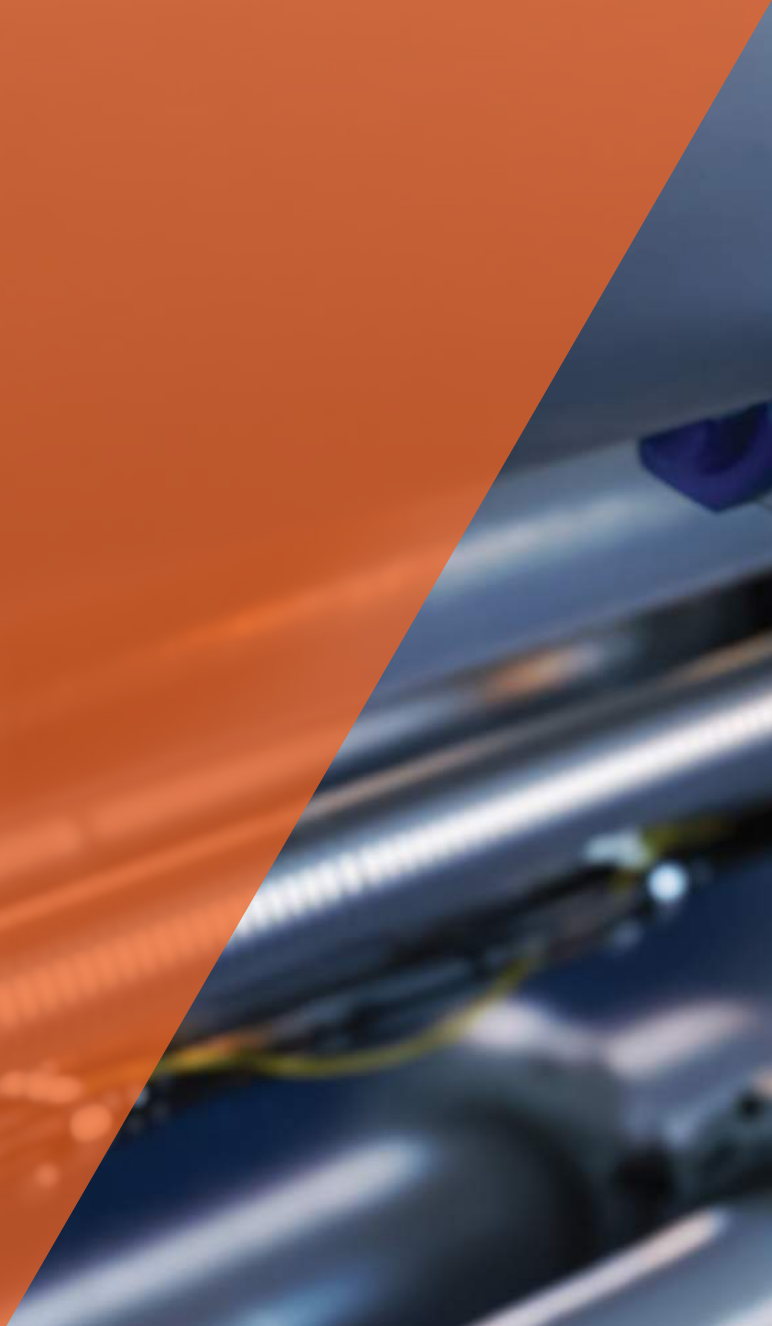



PETROCHEMICAL

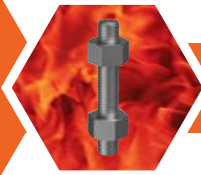

EXCELLENT CORROSION RESISTANCE

PETROCHEMICAL

Wide range of coatings for oil, gas and mining

UNC STUD BOLT & NUT KIT

KSPB7PC
PLN
ASTM A193/A194
Grade B7 2H

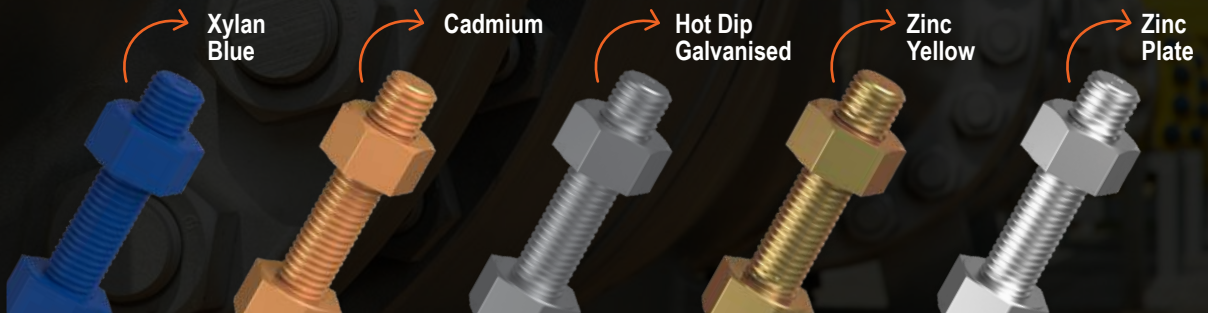

UN8 STUD BOLT & NUT KIT

KSPB7PU
PLN
ASTM A193/A194
Grade B7 2H

UNC STUD BOLT & NUT KIT

KSPB7YC
ZYP
ASTM A193/A194
Grade B7 2H

UN8 STUD BOLT & NUT KIT

KSPB7YU
ZYP
ASTM A193/A194
Grade B7 2H

UNC STUD BOLT & NUT KIT

KSPB7GC
HDG
ASTM A193/A194
Grade B7 2H

UN8 STUD BOLT & NUT KIT

KSPB7GU
HDG
ASTM A193/A194
Grade B7 2H

UNC STUD BOLT & NUT KIT

KSPB7BC
XYB
ASTM A193/A194
Grade B7 2H

UN8 STUD BOLT & NUT KIT

KSPB7BU
XYB
ASTM A193/A194
Grade B7 2H

UNC STUD BOLT

SP82PC
PLN
ASTM A193
Grade B8 CL2

UN8 STUD BOLT

SP82PU
PLN
ASTM A193
Grade B8 CL2

UNC STUD BOLT

SPM2PC
PLN
ASTM A193
Grade B8M CL2

UN8 STUD BOLT

SPM2PU
PLN
ASTM A193
Grade B8M CL2

UN8 STUD BOLT

SPB7CU
CAD
ASTM A193
Grade B7

KEY	
PLN	PLAIN
Z/P	ZINC PLATED (RoHS COMPLIANT)
ZYP	ZINC YELLOW PASSIVATE
HDG	HOT DIP GALVANISED
CAD	CADMIUM
IZSC	ESSO SPEC
XYB	XYLAN BLUE

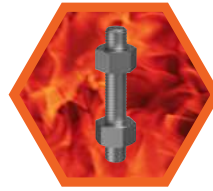



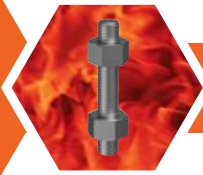

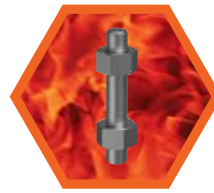

<p>UNC STUD BOLT</p>  <p>SPB7PC</p> <p>PLN ASTM A193 Grade B7</p>	<p>UN8 STUD BOLT</p>  <p>SPB7PU</p> <p>PLN ASTM A193 Grade B7</p>	<p>UNC STUD BOLT</p>  <p>SPB7GC</p> <p>HDG ASTM A193 Grade B7</p>	<p>UN8 STUD BOLT</p>  <p>SPB7GU</p> <p>HDG ASTM A193 Grade B7</p>	<p>UNC STUD BOLT</p>  <p>SPB7BC</p> <p>XYB ASTM A193 Grade B7</p>	<p>UN8 STUD BOLT</p>  <p>SPB7BU</p> <p>XYB ASTM A193 Grade B7</p>	<p>UNC STUD BOLT</p>  <p>SPB7CC</p> <p>CAD ASTM A193 Grade B7</p>
<p>UNC STUD BOLT</p>  <p>SPB7ZC</p> <p>Z/P ASTM A193 Grade B7</p>	<p>UN8 STUD BOLT</p>  <p>SPB7ZU</p> <p>Z/P ASTM A193 Grade B7</p>	<p>UNC STUD BOLT</p>  <p>SPB7YC</p> <p>ZYP ASTM A193 Grade B7</p>	<p>UN8 STUD BOLT</p>  <p>SPB7YU</p> <p>ZYP ASTM A193 Grade B7</p>	<p>UNC STUD BOLT</p>  <p>SPB7IC</p> <p>IZSC ASTM A193 Grade B7</p>	<p>UN8 STUD BOLT</p>  <p>SPB7IU</p> <p>IZSC ASTM A193 Grade B7</p>	<p>UNC ALLTHREAD ROD</p>  <p>APB7PC</p> <p>PLN ASTM A193 Grade B7</p>
<p>UN8 ALLTHREAD ROD</p>  <p>APB7PU</p> <p>PLN ASTM A193 Grade B7</p>	<p>UNC ALLTHREAD ROD</p>  <p>APB7IC</p> <p>IZSC ASTM A193 Grade B7</p>	<p>UN8 ALLTHREAD ROD</p>  <p>APB7IU</p> <p>IZSC ASTM A193 Grade B7</p>	<p>BLANKHEAVY HEX BOLT</p>  <p>BPB7PB</p> <p>PLN ASME B18.2.1 Grade B7</p>	<p>UNC HEAVY HEX BOLT</p>  <p>BPB7PC</p> <p>PLN ASME B18.2.1 Grade B7</p>	<p>UNC HEAVY HEX NUT</p>  <p>NP2HPC</p> <p>PLN ASTM A194 Grade 2H</p>	<p>UN8 HEAVY HEX NUT</p>  <p>NP2HPU</p> <p>PLN ASTM A194 Grade 2H</p>
<p>UNC HEAVY HEX NUT</p>  <p>NP2HGC</p> <p>HDG ASTM A194 Grade 2H</p>	<p>UN8 HEAVY HEX NUT</p>  <p>NP2HGU</p> <p>HDG ASTM A194 Grade 2H</p>	<p>UNC HEAVY HEX NUT</p>  <p>NP2HBC</p> <p>XYB ASTM A194 Grade 2H</p>	<p>UN8 HEAVY HEX NUT</p>  <p>NP2HBU</p> <p>XYB ASTM A194 Grade 2H</p>	<p>UNC HEAVY HEX NUT</p>  <p>NP2HCC</p> <p>CAD ASTM A194 Grade 2H</p>	<p>UN8 HEAVY HEX NUT</p>  <p>NP2HCU</p> <p>CAD ASTM A194 Grade 2H</p>	<p>UNC HEAVY HEX NUT</p>  <p>NP2HZC</p> <p>Z/P ASTM A194 Grade 2H</p>



UN8 HEAVY HEX NUT	UNC HEAVY HEX NUT	UN8 HEAVY HEX NUT	UNC HEAVY HEX NUT	UN8 HEAVY HEX NUT	METRIC HEAVY HEX NUT	UNC HEAVY HEX NUT
NP2HZU	NP2HYC	NP2HYU	NPG4PC	NPG4PU	NPG4PCM	NPG4GC
Z/P ASTM A194 Grade 2H	ZYP ASTM A194 Grade 2H	ZYP ASTM A194 Grade 2H	PLN ASTM A194 Grade 4L	PLN ASTM A194 Grade 4L	PLN ASTM A194M Grade 4L	HDG ASTM A194 Grade 4L
UN8 HEAVY HEX NUT	UNC HEAVY HEX NUT	UN8 HEAVY HEX NUT	UN8 HEAVY HEX NUT	UNC HEAVY HEX NUT	UN8 HEAVY HEX NUT	METRIC HEAVY HEX NUT
NPG4GU	NPG7PC	NPG7PU	NPG7PU3	NPG8PC	NPG8PU	NPG8PCM
HDG ASTM A194 Grade 4L	PLN ASTM A194 Grade 7L	PLN ASTM A194 Grade 7L	PLN ASTM A194 Grade 7	PLN ASTM A194 Grade 8	PLN ASTM A194 Grade 8	PLN ASTM A194M Grade 8
UNC HEAVY HEX NUT	UN8 HEAVY HEX NUT	METRIC HEAVY HEX NUT	UNC HEAVY HEX NUT	UN8 HEAVY HEX NUT	UNC HEAVY HEX NUT	UN8 HEAVY HEX NUT
NP8MPC	NP8MPU	NP8MPCM	NPMAPC	NMAPU	NP8TPC	NP8TPU
PLN ASTM A194 Grade 8M	PLN ASTM A194 Grade 8M	PLN ASTM A194M Grade 8M	PLN ASTM A194 Grade 8MA	PLN ASTM A194 Grade 8MA	PLN ASTM A194 Grade 8T	PLN ASTM A194 Grade 8T
METRIC HEAVY HEX NUT	UNF HEAVY HEX NUT	BSW HEAVY HEX NUT	UNC HEAVY HEX NUT	UN8 HEAVY HEX NUT	UNC HEAVY HEX NUT	UN8 HEAVY HEX NUT
NP2HPCM	NP2HPF	NP2HPW	NP2HWC	NP2HWU	NPHMPC	NPHMPU
PLN ASTM A194M Grade 2H	PLN ASTM A194 Grade 2H	PLN ASTM A194 Grade 2H	ZP XYB ASTM A194 Grade 2H	ZP XYB ASTM A194 Grade 2H	PLN ASTM A194 Grade 2HM	PLN ASTM A194 Grade 2HM



PETROCHEMICAL COATINGS

Icon/Coating		Standard	Coating Thickness	Corrosion Resistance	Description
	HOT DIP GALVANISED	ASTM A153/M	53µm	HIGH	HDG products possess a high level of corrosion resistance and are recommended for long-term outdoor applications.
	ZINC PLATED (ROHS COMPLIANT)	ISO 4042	5µm	LOW	Product is electroplated with zinc which is then passivated with a transparent conversion layer. Z/P products are recommended for indoor and non-corrosive environments.
	ZINC YELLOW PASSIVATE	ISO 4042	5µm	LOW	Product is electroplated with zinc which is then passivated with an iridescent yellow conversion layer. ZYP products are recommended for indoor and non-corrosive environments.
	CADMIUM	ASTM B-766	12µm	MODERATE	Cadmium provides moderate corrosion resistance and is suitable for high-temperature and marine applications. It offers good lubricity for even tensioning and is an exceptional bonding surface for paint and other adhesives.
	1PX1	PROPRIETARY COATING SPECIFICATION	10µm	MODERATE	1PX1 significantly reduces friction coefficient and ensures evenly tensioned fasteners. It provides an excellent undercoat for epoxy paints and has good resistance to acids.
	XYLAN BLUE	PROPRIETARY COATING SPECIFICATION	25µm	HIGH	Xylan Blue significantly reduces friction coefficient and ensures evenly tensioned fasteners. It maintains exceptional corrosion, chemical and weather resistance, and provides an excellent undercoat for epoxy paints. The standard colours are Xylan Blue and Xylan Green.
	NO COATING	-	-	-	No additional coating applied. Products are supplied lightly-oiled to inhibit rust in the packaging and assist with installation.

Hobson holds an extensive range of materials ex-stock, including ASTM A320 L7 and ASTM A193 B16. Specified metals such as duplex stainless and nickel alloys can be sourced upon request.

DRINK FRESH FOOD NOW





NORD-LOCK®



NO MORE LOOSE BOLTS!

NORD-LOCK®

Wedge-locking technology



Swedish
Engineering

<p>METRIC STANDARD WASHER</p> <p>WNHTDDM</p> <p>DELTA PROTEKT® HARDENED STEEL EN 1.7182</p>	<p>IMPERIAL STANDARD WASHER</p> <p>WNHTDD</p> <p>DELTA PROTEKT® HARDENED STEEL EN 1.7182</p>	<p>METRIC LARGE OD WASHER</p> <p>WNHTLDM</p> <p>DELTA PROTEKT® HARDENED STEEL EN 1.7182</p>	<p>Nord-Lock® washers are pre-glued in pairs to facilitate first mounting.</p>			
<p>IMPERIAL LARGE OD WASHER</p> <p>WNHTLD</p> <p>DELTA PROTEKT® HARDENED STEEL EN 1.7182</p>	<p>STANDARD SC WASHER</p> <p>EN 14399: K2</p> <p>WNSCDD</p> <p>DELTA PROTEKT® HARDENED STEEL EN 1.7182</p>	<p>METRIC STANDARD WASHER</p> <p>316</p> <p>WN16DPM</p> <p>AISI 316L STAINLESS STEEL EN 1.4404</p>	<p>IMPERIAL STANDARD WASHER</p> <p>316</p> <p>WN16DP</p> <p>AISI 316L STAINLESS STEEL EN 1.4404</p>	<p>METRIC LARGE OD WASHER</p> <p>316</p> <p>WN16LPM</p> <p>AISI 316L STAINLESS STEEL EN 1.4404</p>	<p>IMPERIAL LARGE OD WASHER</p> <p>316</p> <p>WN16LP</p> <p>AISI 316L STAINLESS STEEL EN 1.4404</p>	<p>METRIC STANDARD WASHER</p> <p>SMO 254</p> <p>WN25DPM</p> <p>SMO 254 STAINLESS STEEL EN 1.4547</p>
<p>METRIC LARGE OD WASHER</p> <p>SMO 254</p> <p>WN25LPM</p> <p>SMO 254 STAINLESS STEEL EN 1.4547</p>	<p>METRIC X SERIES WASHER</p> <p>X Series</p> <p>WNXTDDM</p> <p>DELTA PROTEKT® HARDENED STEEL EN 1.7225</p>	<p>IMPERIAL X SERIES WASHER</p> <p>X Series</p> <p>WNXTDD</p> <p>DELTA PROTEKT® HARDENED STEEL EN 1.7225</p>	<p>X SERIES LARGE OD WASHER</p> <p>X Series</p> <p>WNXTLDM</p> <p>DELTA PROTEKT® HARDENED STEEL EN 1.7225</p>	<p>STANDARD WASHER KIT</p> <p>WNXAHT</p> <p>DELTA PROTEKT® HARDENED STEEL EN 1.7182</p>	<p>STANDARD WASHER KIT</p> <p>316</p> <p>WNXASS</p> <p>AISI 316L STAINLESS STEEL EN 1.4404</p>	<p>WHEEL NUT</p> <p>NL10DNM</p> <p>DELTA PROTEKT® CLASS 10</p>



NORD-LOCK® WASHER MATERIAL / TYPE GUIDE

APPLICATION PARAMETER	STEEL WASHERS	STAINLESS STEEL WASHERS	254 SMO® WASHERS	INCONEL®/ HASTELLOY® C-276 WASHERS	INCONEL® 718 WASHERS
STEEL TYPE (EN)	1.7182	1.4404	1.4547	2.4819 or equivalent	2.4667 or equivalent
EXAMPLES OF APPLICATIONS	General steel applications	General stainless steel applications. Non-chlorine/acid environments	General salt water applications, pumps, chloride, heat exchangers, nuclear, desalination, food processing and medical equipment	General acidic environments, process and chemical industry, evaporators, offshore downhole tooling	Applications with high temperatures, gas turbines, turbo charges, incinerators
AVAILABLE FOR BOLT SIZES	M3-M130	M3-M80	M3-M39	M3-M39	M3-M39
TREATMENT SURFACE COATING	Through hardened Delta Protekt® base coat (KL100) and top coat (VH302GZ)	Surface hardened	Surface hardened	Surface hardened	Surface hardened
WASHER HARDNESS*	≥ 465 HV1	≥ 520HV0,05	≥ 600HV0,05	≥ 520HV0,05	≥ 620HV0,05
CORROSION RESISTANCE	Minimum 1000 hours in salt spray test (according to ISO9227)	PREN 27**	PREN 45**	PREN 68**	PREN 29**
BOLT GRADES	Up to 12.9	Up to A4-80	Up to A4-80	-	-
TEMPERATURE RANGE***	-50°C to 200°C	-160°C to 500°C	-160°C to 500°C	-160°C to 500°C	-160°C to 700°C

* In order to ensure the unique mechanical locking function of the Nord-Lock® washers, the hardness of the mating surfaces must be lower than the hardness of the Nord-Lock® washers (see table above).

** PREN (Pitting Resistance Equivalent Number) = %Cr + ³/₃x%Mo + ¹⁶/₁₆x%N. The table figures are valid for base material. A higher PREN indicates better corrosion resistance.

*** Temperature recommendations are based on information from tests and the raw material supplier. The locking function is not affected within the specification.



SUPERBOLT™

PART OF THE NORD-LOCK GROUP

Superbolt™ tensioners are designed as direct replacements for conventional nuts and bolts. These devices can be threaded onto a new or existing bolt, stud, threaded rod or shaft.

THE SUPERBOLT™ PRINCIPLE

The main thread serves to position the tensioner on the bolt or stud against the hardened washer and the loadbearing surface. Once it is positioned, actual tensioning of the bolt or stud is accomplished with simple hand tools by torqueing the jackbolts that encircle the main thread.

The jackbolts transfer the preload evenly into the main thread and, onto the joint. The main thread is tightened in pure tension. The multi-jackbolt tensioners offer you simple and cost-effective tightening for large size bolts.

- 1** By tightening the jackbolts, a strong thrust (axial) force is generated. This thrust force is directed against a hardened washer. Jackbolts have a small friction diameter and can create a high thrust force with relatively little torque input.
- 2** The loads are transferred through the nut body which is positioned on the main thread by hand.
- 3** A hardened washer is used to transfer the force while protecting the flange face.
- 4** The thrust (axial) force of jackbolts and the opposite reaction force of the main bolt head create a strong clamping force on the flange.
- 5** The thrust (axial) force from the jackbolt creates an equally strong reaction force in the main bolt.

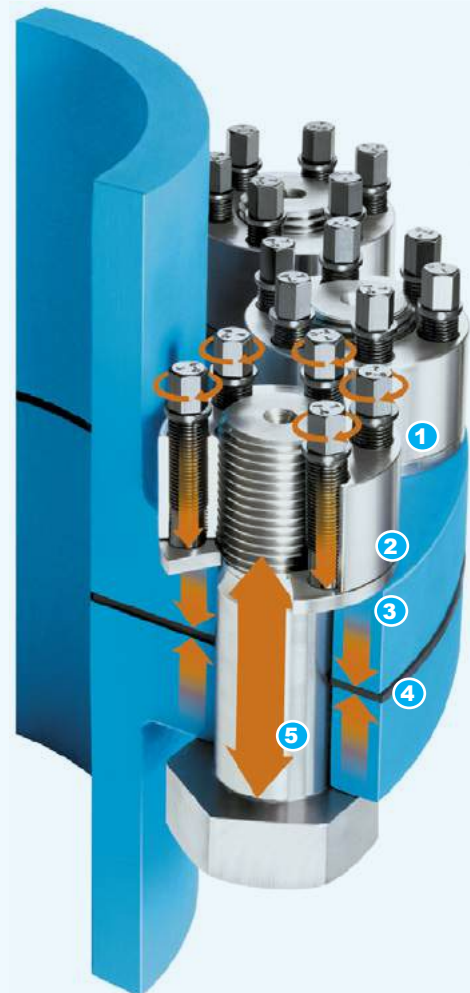



Expander®

A permanent solution for pivot wear

Expander® offers an advanced, cost-effective solution that permanently prevents pivot wear. With Expander®, repairs can be carried out directly in the worn mountings without welding and line-boring.

THE EXPANDER® SYSTEM

The assembly includes an axle tapered at both ends, two expansion sleeves, two tension washers and two fasteners. When the fasteners are torqued, the tension washers push the expansion sleeves up the tapered part of the pin, locking the system into the lug ears and eliminating movement that causes pivot wear.

The double-sided locking mechanism provides increased stability, security and a backlash-free joint. Installation can be easily done in the field, reducing downtime and cost.

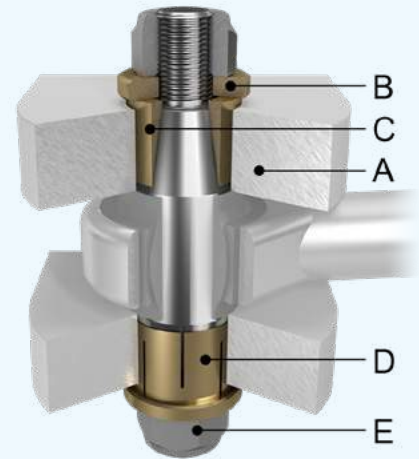

- A** Expander® System is installed directly into the existing mounting without expensive welding and line-boring.
- B** Upon tightening the fasteners, the washer presses the slotted expansion sleeve up the tapered ends of the pin.
- C** The sleeves expand, conform with the wear pattern and lock the system in the lug ears.
- D** Once retorqued according to the instructions, the system will lock from both sides and significantly increase stability.
- E** Easy to remove and reinstall compared to regular straight pins.

Conventional pins have axial locking only, but the Expander® System consists of both radial and axial locking. This gives a stronger box construction to the whole machine pivot. The sleeves expand over both ends of the tapered axle and lock securely even in worn lug holes. If the hole has been worn oval, the Expander® System fills out the ovality and ensures a secure solution without any preparatory machining.

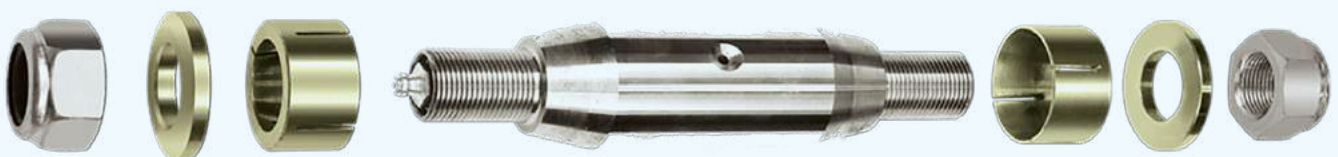

SUPERBOLT™ and EXPANDER® can be ordered on request.

SCHEINORR





SCHNORR®



SCHNORR[®]



German Engineering

Disc spring engineering

<p>DISC SPRING</p>  <p>WOHTDP</p> <p>PLN DIN EN 16983*</p>	<p>DISC SPRING</p>  <p>WOHTDG</p> <p>MGAL DIN EN 16983*</p>	<p>DISC SPRING</p> <p>304</p>  <p>WO04DP</p> <p>304 STAINLESS STEEL DIN EN 16983*</p>	<p>DISC SPRING</p>  <p>WOHTDF</p> <p>ZFS DIN EN 16983*</p>	<p>BEARING PRELOAD SPRING</p>  <p>WOHTKP</p> <p>PLN TYPE K NON-SLOTTED</p>	<p>* DIN EN 16983 replaced DIN 2093 on 1 February 2017.</p>	
<p>TYPE S SAFETY WASHER</p> <p>SERRATED</p>  <p>WOHTSZM</p> <p>Z/P SERRATED</p>	<p>TYPE S SAFETY WASHER</p> <p>SERRATED</p>  <p>WOHTSPM</p> <p>PLN SERRATED</p>	<p>TYPE VS SAFETY WASHER</p> <p>SERRATED</p>  <p>WOHTVZM</p> <p>Z/P SERRATED</p>	<p>TYPE VS SAFETY WASHER</p> <p>SERRATED</p>  <p>WOHTVPM</p> <p>PLN SERRATED</p>	<p>TYPE S SAFETY WASHER</p> <p>304 SERRATED</p>  <p>WO04SPM</p> <p>304 STAINLESS STEEL SERRATED</p>	<p>TYPE VS SAFETY WASHER</p> <p>304 SERRATED</p>  <p>WO04VPM</p> <p>304 STAINLESS STEEL SERRATED</p>	<p>SCHNORR[®] Safety Washers are in the form of a disc spring and have serrations on both sides to offer an excellent anti-vibration solution.</p>
<p>HDS LOAD HEAVY DUTY WASHER</p>  <p>WOHTHZM</p> <p>Z/P DIN 6796</p>	<p>HDS LOAD HEAVY DUTY WASHER</p>  <p>WOHTHPM</p> <p>PLN DIN 6796</p>	<p>HDS LOAD HEAVY DUTY WASHER</p>  <p>WOHTHYM</p> <p>ZYP 25µm DIN 6796</p>	<p>HDS LOAD HEAVY DUTY WASHER</p>  <p>WOHTHFM</p> <p>ZFS DIN 6796</p>	<p>HS LOAD HIGH STRESS WASHER</p>  <p>WOHTLZM</p> <p>Z/P DIN 267</p>	<p>HS LOAD HIGH STRESS WASHER</p>  <p>WOHTLPM</p> <p>PLN DIN 267</p>	<p>HS LOAD HIGH STRESS WASHER</p>  <p>WOHTLEM</p> <p>GEOMET 321B DIN 267</p>



**MANAGING MAXIMUM
FORCE IN EXTREME
CONDITIONS**



Safety Washers:

- » High resistance to vibration
- » Patented technology
- » Extensive range



Disc Springs

- » Space saver with high spring force
- » No setting or fatigue under normal loads
- » Long service life

NEPTUNE





NEPTUNE®



A4 - 80

NEPTUNE®

High-Tensile Stainless

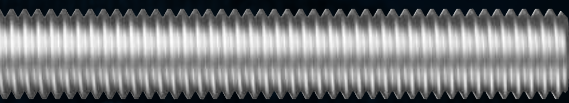

METRIC NEPTUNE® ROD

316



AL16NCM

316
STAINLESS STEEL
DIN 975 / A4-80

METRIC NEPTUNE® HEX BOLT

316



BH16NCM

316
STAINLESS STEEL
DIN 931 / A4 - 80

METRIC NEPTUNE® SET SCREW

316



BS16NCM

316
STAINLESS STEEL
DIN 933 / A4-80

METRIC NEPTUNE® SOCKET SCREW

316



SH16NCM

316
STAINLESS STEEL
DIN 912 / A4-80

METRIC NEPTUNE® HEX NUT

316

NYLOC

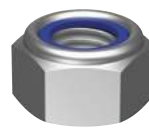

NN16NCM

316
STAINLESS STEEL
DIN 985 / A4-80

NYLOC®

The special nylon insert prevents loosening caused by vibration.



METRIC NEPTUNE® HEX NUT

316



NH16NCM

316
STAINLESS STEEL
DIN 934 / A4-80

METRIC NEPTUNE® FLAT ROUND WASHER

316



WR16NM

316
STAINLESS STEEL
HEC 125A / A4-80

NEW METRIC NEPTUNE® SPRING WASHER

316



WR16NSM

316
STAINLESS STEEL
HEC 7980 / A4-80

Spring Washer

FOR USE WITH NEPTUNE BOLTS AND NUTS

Neptune® spring washers have superior hardness to standard spring washers to accommodate the **higher tensile loads** achieved in a Neptune® assembly.

→ Square section





Breaking Strength Comparison

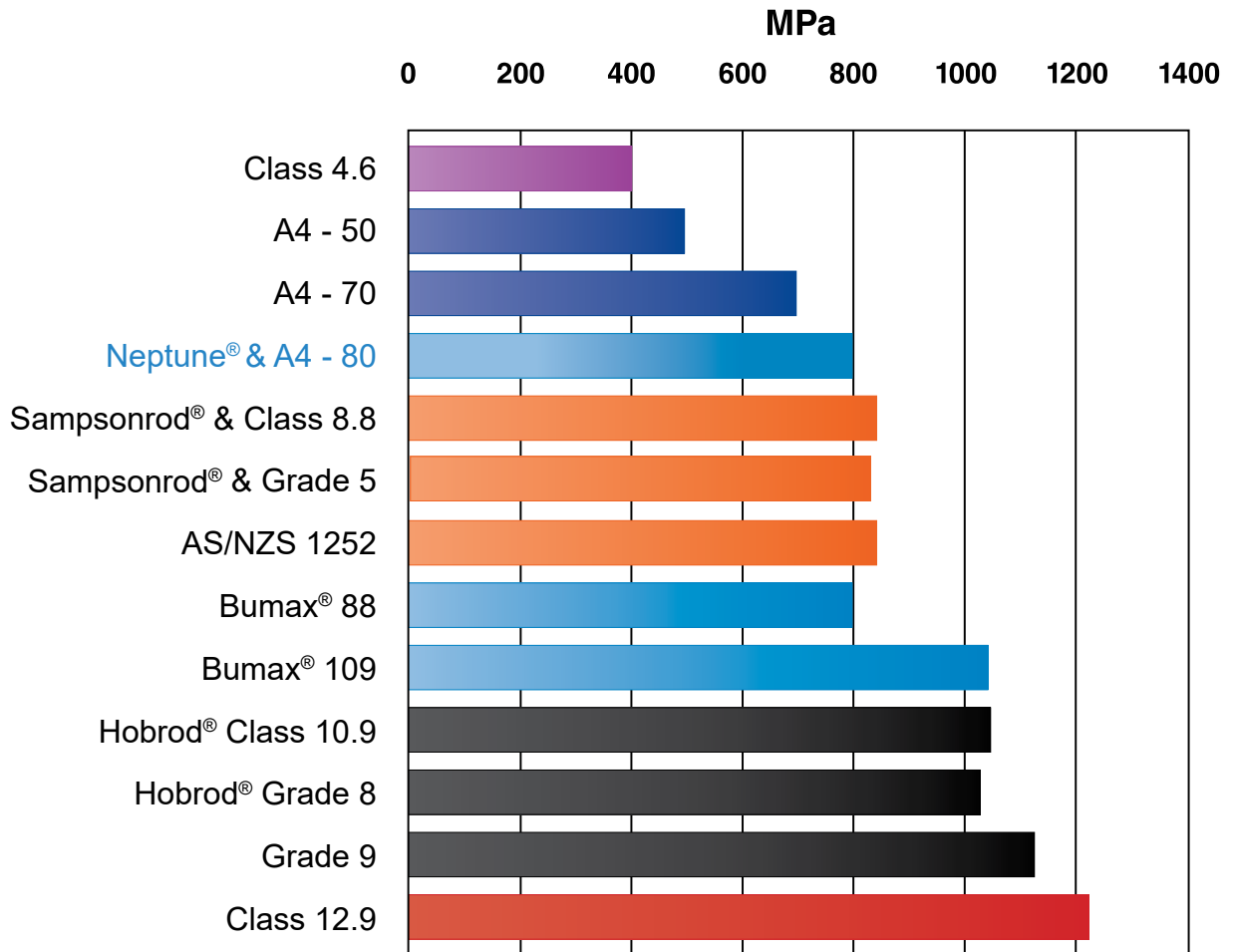

A4-80

HIGH STRENGTH STAINLESS STEEL

BUWMAX





BUMAX[®]

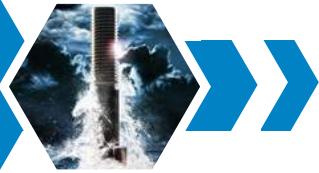

BUMAX®
THE WORLD'S STRONGEST
STAINLESS STEEL BOLT

METRIC ALLTHREAD ROD

ALB8PCM

BUMAX® 88
DIN 976

METRIC HEX BOLT

BHB8PCM

BUMAX® 88
ISO 4014

UNC HEX BOLT

BHB8PC

BUMAX® 88
ANSI B18.2.1

METRIC HEX SET SCREW

BSB8PCM

BUMAX® 88
ISO 4017

METRIC CAP SCREW SOCKET

SHB8PCM

BUMAX® 88
ISO 4762

UNC CAP SCREW SOCKET

SHB8PC

BUMAX® 88
ANSI B18.3

METRIC CSK FLAT SOCKET

SCB8PCM

BUMAX® 88
ISO 10642

METRIC HEX NUT

NHB8PCM

BUMAX® 88
ISO 4032

UNC HEX NUT

NHB8PC

BUMAX® 88
DIN 934

METRIC HEX FLANGE NUT

NFB8PCM

BUMAX® 88
ISO 4161

METRIC HEX FLANGE LOCK NUT

NLB8FCM

BUMAX® 88

METRIC COLLARED HEX LOCK NUT

NLB8CCM

BUMAX® 88

METRIC FLAT ROUND WASHER

WRB8PCM

BUMAX® 88
ISO 7089

IMPERIAL FLAT ROUND WASHER

WRB8P

BUMAX® 88
ISO 7089

METRIC FLAT ROUND WASHER

WRB8EM

BUMAX® 88
ISO 7089
GEOMET

METRIC MUDGUARD WASHER

WRB8MM

BUMAX® 88
ISO 7093

METRIC HEX BOLT

BHB9PCM

BUMAX® 109
ISO 4014

METRIC HEX SET SCREW

BSB9PCM

BUMAX® 109
ISO 4017

METRIC SOCKET HEAD CAP SCREW

SHB9PCM

BUMAX® 109
ISO 4762

METRIC HEX NUT

NHB9PCM

BUMAX® 109
ISO 4032

METRIC FLAT ROUND WASHER

WRB9PM

BUMAX® 109
ISO 7089

METRIC SOCKET HEAD CAP SCREW

SHX9PCM

BUMAX® DX 129
ISO 4762

KEY

BUMAX® 88

EQUIVALENT TO CLASS 8.8 TENSILE STRENGTH

BUMAX® 109

EQUIVALENT TO CLASS 10.9 TENSILE STRENGTH

BUMAX® DX 129

EQUIVALENT TO CLASS 12.9 TENSILE STRENGTH

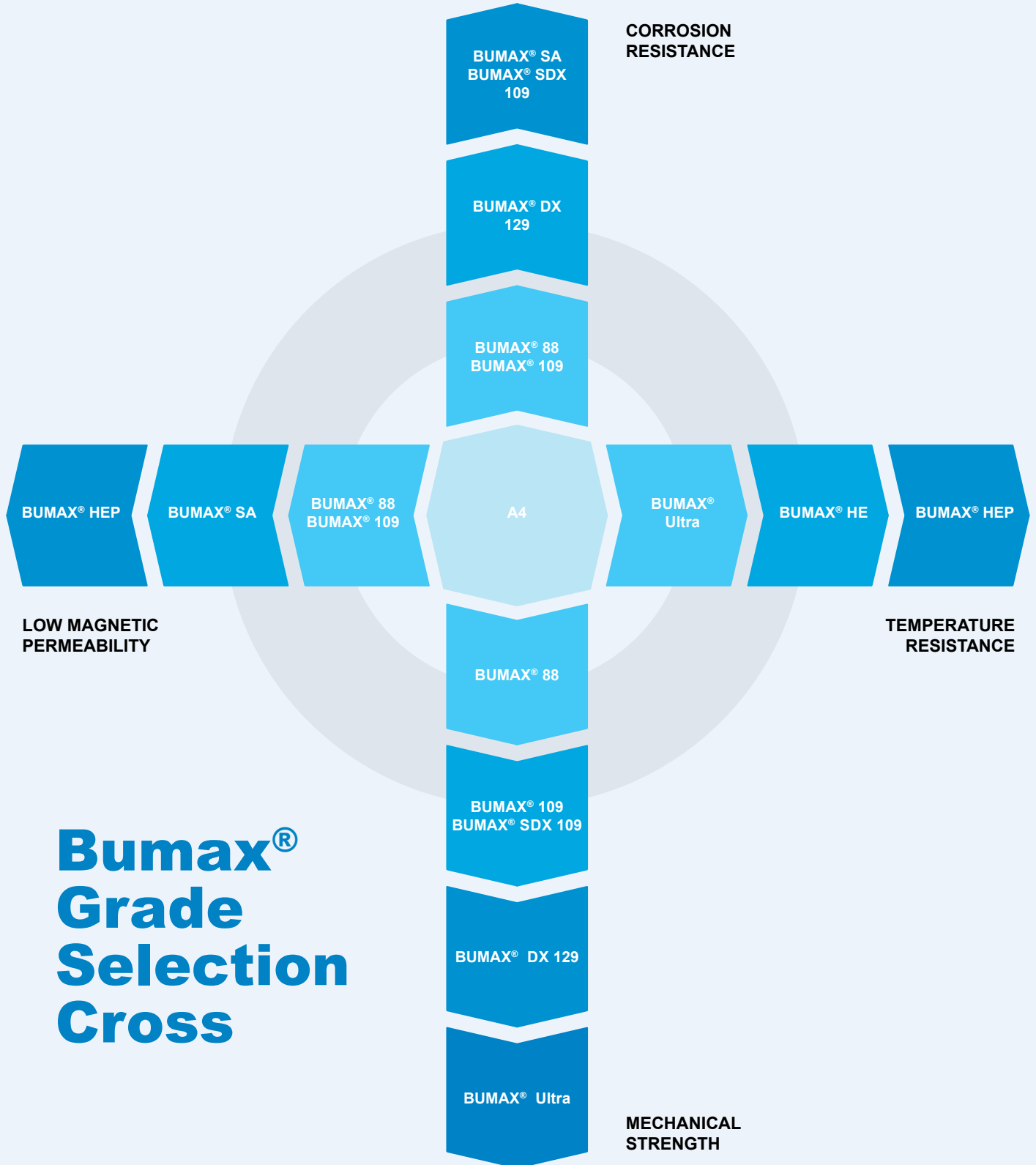

THE
DOD
BRAND
TIRE

BOX
BOX
BOX





Quality
Fasteners

TRADE PAX™



TRADE PAX



TRADE PAX™

All of your favourite fasteners are now available in handy hang packs.



Product types available in **TRADE PAX™**



BOLTS



ANCHORS



SELF-DRILLING SCREWS



NUTS



MACHINE SCREWS



HARDWARE



WASHERS



SELF-TAPPING SCREWS



RIVETS



TRADE PAX™

Find all our **TRADE PAX™** online



Go to **hobson.com.au** and click on **TRADE PAX™** to find the complete range of products in a handy hang pack.



Find additional technical information, relevant documents and more!

STAINLESS STEEL HARDWARE



STAINLESS HARDWARE















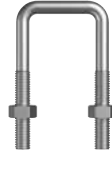
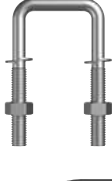





STAINLESS HARDWARE



<p>D SHACKLE STANDARD</p> <p>316</p>  <p>HSH16DSM</p> <p>316 STAINLESS STEEL A4</p>	<p>D SHACKLE CAPTIVE PIN</p> <p>316</p>  <p>HSH16CPM</p> <p>316 STAINLESS STEEL A4</p>	<p>D SHACKLE LONG</p> <p>316</p>  <p>HSH16LGM</p> <p>316 STAINLESS STEEL A4</p>	<p>D SHACKLE LIGHTWEIGHT</p> <p>304</p>  <p>HSH04LWM</p> <p>304 STAINLESS STEEL A2</p>	<p>D SHACKLE INTERNAL HEX PIN</p> <p>316</p>  <p>HSH16HPM</p> <p>316 STAINLESS STEEL A4</p>	<p>D SHACKLE WIDE MOUTH</p> <p>316</p>  <p>HSH16WMM</p> <p>316 STAINLESS STEEL A4</p>	<p>D SHACKLE BOW</p> <p>316</p>  <p>HSH16BWM</p> <p>316 STAINLESS STEEL A4</p>
<p>SHACKLE TWISTED</p> <p>316</p>  <p>HSH16TWM</p> <p>316 STAINLESS STEEL A4</p>	<p>D SHACKLE DOUBLE BAR</p> <p>316</p>  <p>HSH16DBM</p> <p>316 STAINLESS STEEL A4</p>	<p>SHACKLE REPLACEMENT PIN</p> <p>316</p>  <p>HXPINS</p> <p>316 STAINLESS STEEL A4</p>	<p>SWIVEL EYE + SNAP</p> <p>316</p>  <p>HSW16EP</p> <p>316 STAINLESS STEEL A4</p>	<p>SWIVEL EYE + EYE</p> <p>316</p>  <p>HSW16EE</p> <p>316 STAINLESS STEEL A4</p>	<p>SWIVEL JAW + JAW</p> <p>316</p>  <p>HSW16JJ</p> <p>316 STAINLESS STEEL A4</p>	<p>SWIVEL EYE + SNAP SHACKLE</p> <p>316</p>  <p>HSW16EK</p> <p>316 STAINLESS STEEL A4</p>
<p>SWIVEL JAW + SNAP SHACKLE</p> <p>316</p>  <p>HSW16JK</p> <p>316 STAINLESS STEEL A4</p>	<p>S HOOK</p> <p>304</p>  <p>HHK04S</p> <p>304 STAINLESS STEEL A2</p>	<p>SNAP HOOK CAST</p> <p>316</p>  <p>HHK16CP</p> <p>316 STAINLESS STEEL A4</p>	<p>SPRING HOOK ASYMMETRIC</p> <p>316</p>  <p>HHK16SA</p> <p>316 STAINLESS STEEL A4</p>	<p>SNAP HOOK SAFETY LATCH</p> <p>316</p>  <p>HHK16CL</p> <p>316 STAINLESS STEEL A4</p>	<p>SNAP HOOK RIGID EYE</p> <p>316</p>  <p>HHK16CR</p> <p>316 STAINLESS STEEL A4</p>	<p>SPRING HOOK</p> <p>316</p>  <p>HHK16SP</p> <p>316 STAINLESS STEEL A4</p>
<p>SPRING HOOK EYE</p> <p>316</p>  <p>HHK16SE</p> <p>316 STAINLESS STEEL A4</p>	<p>SPRING HOOK EYE & NUT</p> <p>316</p>  <p>HHK16SN</p> <p>316 STAINLESS STEEL A4</p>	<p>PELICAN HOOK</p> <p>316</p>  <p>HHK16PEM</p> <p>316 STAINLESS STEEL A4</p>	<p>PAD EYE DIAMOND</p> <p>304</p>  <p>HEP04DI</p> <p>304 STAINLESS STEEL A2</p>	<p>PAD EYE OVAL</p> <p>304</p>  <p>HEP04OV</p> <p>304 STAINLESS STEEL A2</p>	<p>PAD EYE OBLONG</p> <p>304</p>  <p>HEP04OB</p> <p>304 STAINLESS STEEL A2</p>	<p>PAD EYE OBLONG & RING</p> <p>304</p>  <p>HEP04OR</p> <p>304 STAINLESS STEEL A2</p>



<p>PAD EYE ROUND BOLT</p> <p>304</p>  <p>HEP04RB</p> <p>304 STAINLESS STEEL A2</p>	<p>PAD EYE ROUND</p> <p>304</p>  <p>HEP04RD</p> <p>304 STAINLESS STEEL A2</p>	<p>PAD EYE ROUND OPEN</p> <p>304</p>  <p>HEP04RO</p> <p>304 STAINLESS STEEL A2</p>	<p>U BOLT KIT ROUND</p> <p>316</p>  <p>KUR16PCM</p> <p>316 STAINLESS STEEL A4</p>	<p>U BOLT KIT + PLATE & CRIMP</p> <p>304</p>  <p>HUR04KPM</p> <p>304 STAINLESS STEEL A2</p>	<p>U BOLT KIT SQUARE</p> <p>316</p>  <p>KUS16PCM</p> <p>316 STAINLESS STEEL A4</p>	<p>U BOLT KIT SQUARE WITH SPRING WASHER</p> <p>316</p>  <p>KUS16PSM</p> <p>316 STAINLESS STEEL A4</p>
<p>CHAIN LINK CLIP POLISHED</p> <p>316</p>  <p>HCH16LC</p> <p>316 STAINLESS STEEL A4</p>	<p>CHAIN LINK QUIK POLISHED</p> <p>316</p>  <p>HCH16LQ</p> <p>316 STAINLESS STEEL A4</p>	<p>WELDED RING DEE</p> <p>304</p>  <p>HRG04WD</p> <p>304 STAINLESS STEEL A2</p>	<p>WELDED RING TRIANGLE</p> <p>304</p>  <p>HRG04WT</p> <p>304 STAINLESS STEEL A2</p>	<p>WELDED RING ROUND</p> <p>304</p>  <p>HRG04WR</p> <p>304 STAINLESS STEEL A2</p>	<p>WELDED RING ROUND</p> <p>316</p>  <p>HRG16WR</p> <p>316 STAINLESS STEEL A4</p>	<p>CHAIN LINK REGULAR POLISHED</p> <p>316</p>  <p>HCH16LP</p> <p>316 STAINLESS STEEL A4</p>
<p>EYE BOLT KIT COLLAR</p> <p>316</p>  <p>HEC16KM</p> <p>316 STAINLESS STEEL A4</p>	<p>LAG SCREW EYE COLLAR</p> <p>316</p>  <p>HES16CL</p> <p>316 STAINLESS STEEL A4</p>	<p>EYE BOLT KIT</p> <p>304</p>  <p>HEB04PM</p> <p>304 STAINLESS STEEL A2</p>	<p>EYE NUT COLLAR</p> <p>316</p>  <p>HEN16PM</p> <p>316 STAINLESS STEEL A4</p>	<p>EYE BOLT COLLAR</p> <p>316</p>  <p>HEC16PM</p> <p>316 STAINLESS STEEL A4</p>	<p>NEW EYE NUT COLLAR</p> <p>316</p>  <p>HEN16P5M</p> <p>316 STAINLESS STEEL HEC 582 / A4</p>	



PIANO HINGE DRILLED

304



HHP04D

304 STAINLESS STEEL A2

PIANO HINGE UNDRILLED

304



HHP04U

304 STAINLESS STEEL A2

304 STAINLESS STEEL

HINGES

Use with countersunk screws for flush finish.

DRILLX

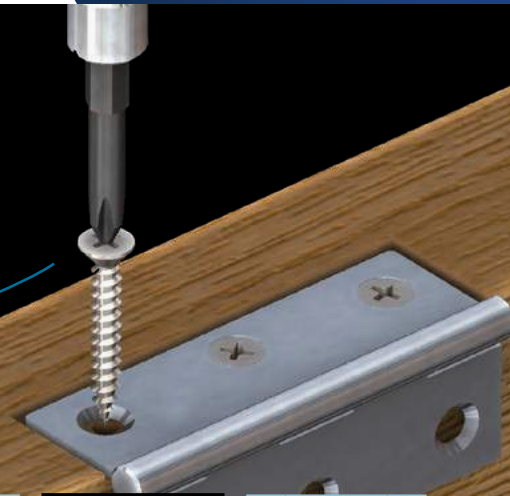

BUTT HINGE 4 HOLE FIXED PIN

304



HHB04D-050

304 STAINLESS STEEL A2

BUTT HINGE 6 HOLE FIXED PIN

304



HHB04D-075

304 STAINLESS STEEL A2

BUTT HINGE 8 HOLE FIXED PIN

304



HHB04D-100

304 STAINLESS STEEL A2

NEW BUTT HINGE 8 HOLE LOOSE PIN

304



HHB04L

304 STAINLESS STEEL A2

FLUSH FITTING HINGE

304



HHF04D-100

304 STAINLESS STEEL A2

FLUSH FITTING HINGE



HHFALD-100

ALUMINIUM HEC

HATCH HINGE EVEN

304



HHH04E

304 STAINLESS STEEL A2

HATCH HINGE UNEVEN

304



HHH04U

304 STAINLESS STEEL A2

HATCH HINGE EVEN

316



HHH16E

316 STAINLESS STEEL A4

HATCH HINGE UNEVEN

316



HHH16U

316 STAINLESS STEEL A4

TOGGLE LATCH ADJUSTABLE

304

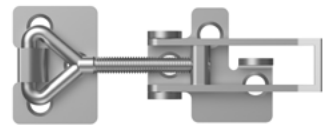

HLT04A

304 STAINLESS STEEL A2

MULTI-GRIP

316



HGM16D

316 STAINLESS STEEL A4

TRIPLE-GRIP LEFT HAND

316



HGT16L

316 STAINLESS STEEL A4

TRIPLE-GRIP RIGHT HAND

316



HGT16R

316 STAINLESS STEEL A4

JOIST HANGER

316

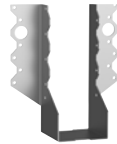

HHJ16D

316 STAINLESS STEEL A4

Joist Hanger

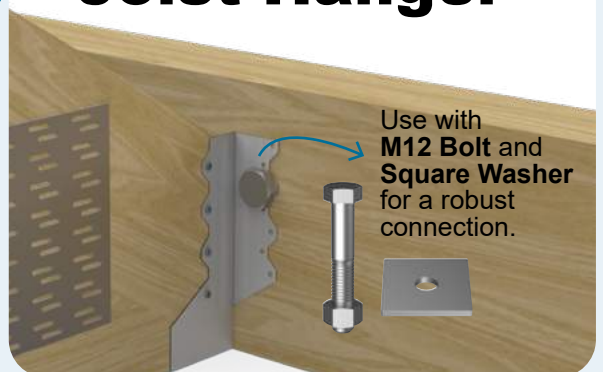

Use with M12 Bolt and Square Washer for a robust connection.



WIRE ROPE
7x19
FLEXIBLE

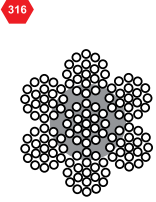

HRW16719

316
STAINLESS STEEL
A4

WIRE ROPE
7x7
WORKABLE

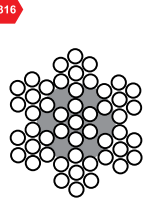

HRW16707

316
STAINLESS STEEL
A4

WIRE ROPE
7x7 PVC
COATED

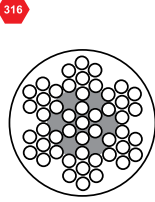

HRW16707P

316
STAINLESS STEEL
A4

WIRE ROPE
1x19
RIGID

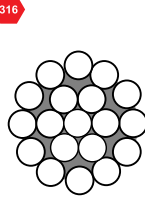

HRW16119

316
STAINLESS STEEL
A4

316



Wire Rope

- » 3.2mm
- » 305m per roll
- » 100m and 1000m rolls also available

WIRE ROPE CUTTER



HTHRC-008

TOOL HAND
CUT up to 5.0
WIRE ROPE

WIRE ROPE CUTTER



HTHRC-450

TOOL HAND
CUT up to 12.0
WIRE ROPE

WIRE ROPE CUTTER



HTHRC-800

TOOL HAND
CUT up to 16.0
WIRE ROPE

CUTTING AND SWAGING COMBO



HTHSC-350

TOOL HAND
CUT up to 3.5
WIRE ROPE

CUTTING AND SWAGING COMBO



HTHSC-600

TOOL HAND
CUT up to 5.0
WIRE ROPE

Cutting Tool

- » Designed for cutting wire rope and piano steel wire
- » Comfortable rubber grip handles
- » Shear cut blades give a clean sharp cut

Swaging Tool

- » Designed for swaging or crimping copper or aluminium swages.
- » Forged alloy steel heat-treated jaws designed to produce a tight clean compression of copper and aluminium swages.





304 & 316 STAINLESS STEEL

BALUSTRADE

Imagine. Create. Transform.

Check out our wide range of Balustrade Solutions at hobson.com.au



<p>TERMINAL SWAGE FORK</p> <p>316</p>  <p>HTS16FK</p> <p>316 STAINLESS STEEL A4</p>	<p>TERMINAL SWAGE FORK MINI TYPE</p> <p>316</p>  <p>HTS16FM</p> <p>316 STAINLESS STEEL A4</p>	<p>TERMINAL SWAGE FORK TOGGLE</p> <p>316</p>  <p>HTS16FT</p> <p>316 STAINLESS STEEL A4</p>	<p>TERMINAL SWAGE STUD MINI</p> <p>316</p>  <p>HTS16MT</p> <p>316 STAINLESS STEEL A4</p>	<p>TERMINAL SWAGE EYE</p> <p>316</p>  <p>HTS16EY</p> <p>316 STAINLESS STEEL A4</p>	<p>TERMINAL SWAGE BUTTON HEAD</p> <p>316</p>  <p>HTS16BH</p> <p>316 STAINLESS STEEL A4</p>	<p>LAG EYE SCREW</p> <p>316</p>  <p>HES16PL</p> <p>316 STAINLESS STEEL A4</p>
<p>WIRE ROPE THIMBLE CLOSED</p> <p>304</p>  <p>HXTH04N</p> <p>304 STAINLESS STEEL A2</p>	<p>WIRE ROPE THIMBLE OPEN</p> <p>304</p>  <p>HXTH04O</p> <p>304 STAINLESS STEEL A2</p>	<p>MACHINE FERRULE</p>  <p>HXFEM</p> <p>NICKEL PLATED COPPER HEC</p>	<p>HAND FERRULE</p>  <p>HXFEH</p> <p>NICKEL PLATED COPPER HEC</p>	<p>SOCKET DRIVE FOR LAG SCREWS</p>  <p>HXSD</p> <p>MGAL HEC</p>		



CROSS CONNECTOR		BLACK BUSH SPLIT TYPE		BEVELLED WASHER		KEY			
304						KEY			
	HXCC04		HXNBB		HXWBBC	CHR CHROME PLATE			
	304 STAINLESS STEEL A2		NYLON		CHROME BRASS HEC	BRASS BRASS			
WIRE ROPE SHELF SUPPORT CLIP		ROUND BALL INTERNAL THREADED		ROUND BALL		MGAL MECHANICAL GALVANISED			
316		316		316		ALUM ALUMINIUM			
	HXSS16		HXRB16TM		HXRB16	NY UV NYLON BLACK UV STABLE			
	316 STAINLESS STEEL A4		316 STAINLESS STEEL A4		316 STAINLESS STEEL A4	SS STAINLESS STEEL			
RETAINING CLIP		SADDLE EYE STRAP		WIRE ROPE GRIP		STEEL STEEL			
316		304		316					
	HXRC		HED04ST		HXRW16G				
	316 STAINLESS STEEL A4		304 STAINLESS STEEL A2		316 STAINLESS STEEL A4				
TIMBER INS CSK HEX SOCKET L/H		EYE SCREW METAL THREAD		HEAD TENSIONER ALLEN KEY					
316		316		304					
	HXTI16CLM		HES16PCM		HXHT04AK				
	316 STAINLESS STEEL A4		316 STAINLESS STEEL A4		304 STAINLESS STEEL A2				
TIMBER INS CSK HEX SOCKET R/H		CLEVIS REPLACEMENT PIN		HEAD TENSIONER HEX HEAD					
316		316		304					
	HXTI16CRM		HXPINC		HXHT04HH				
	316 STAINLESS STEEL A4		316 STAINLESS STEEL A4		304 STAINLESS STEEL A2				



**STAINLESS
BALUSTRADE**



Terminal Swages, Rigging Screws & Turnbuckles

**NEW RIGGING
SCREW
HOOK + JAW**

316

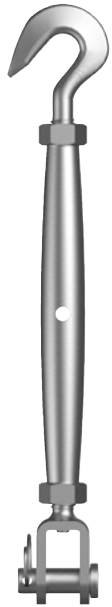

HRS16HJ

**316
STAINLESS STEEL
A4**

Stud

Swage

Screw















Hook

Eye

Jaw

Toggle



<p>RIGGING SCREW EYE + EYE</p> <p>316</p>  <p>HRS16EE</p> <p>316 STAINLESS STEEL A4</p>	<p>RIGGING SCREW LAG + SWAGE</p> <p>316</p>  <p>HRS16LS</p> <p>316 STAINLESS STEEL A4</p>	<p>RIGGING SCREW JAW + JAW</p> <p>316</p>  <p>HRS16JJ</p> <p>316 STAINLESS STEEL A4</p>	<p>RIGGING SCREW JAW + SWAGE</p> <p>316</p>  <p>HRS16JS</p> <p>316 STAINLESS STEEL A4</p>	<p>RIGGING SCREW TGLE + SWAGE</p> <p>316</p>  <p>HRS16TS</p> <p>316 STAINLESS STEEL A4</p>	<p>TERMINAL SWAGE INTERNAL THREADED</p> <p>316</p>  <p>HTS16IT</p> <p>316 STAINLESS STEEL A4</p>	<p>TERMINAL SWAGE LAG SCREW LEFT</p> <p>316</p>  <p>LEFT HAND</p> <p>HTS16LL</p> <p>316 STAINLESS STEEL A4</p>
<p>TERMINAL SWAGE LAG SCREW RIGHT</p> <p>316</p>  <p>HTS16RL</p> <p>316 STAINLESS STEEL A4</p>	<p>TERMINAL SWAGE STUD RIGHT HAND</p> <p>316</p>  <p>HTS16ST</p> <p>316 STAINLESS STEEL A4</p>	<p>TERMINAL SWAGE STUD LEFT HAND</p> <p>316</p>  <p>LEFT HAND</p> <p>HTS16SL</p> <p>316 STAINLESS STEEL A4</p>	<p>TURNBUCKLE OPEN BODY HOOK + EYE</p> <p>316</p>  <p>HTB16HE</p> <p>316 STAINLESS STEEL A4</p>	<p>TURNBUCKLE OPEN BODY HOOK + HOOK</p> <p>316</p>  <p>HTB16HH</p> <p>316 STAINLESS STEEL A4</p>	<p>TURNBUCKLE OPEN BODY JAW + JAW</p> <p>316</p>  <p>HTB16JJ</p> <p>316 STAINLESS STEEL A4</p>	<p>TURNBUCKLE OPEN BODY EYE + EYE</p> <p>316</p>  <p>HTB16EE</p> <p>316 STAINLESS STEEL A4</p>

STATISTICS FAST LINES





STAINLESS FASTENERS

















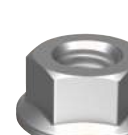
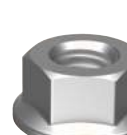

STAINLESS FASTENERS

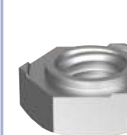
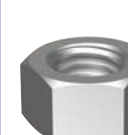
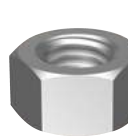
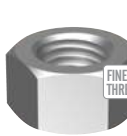

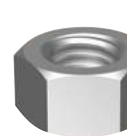
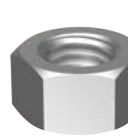
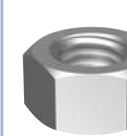
<p>METRIC ALLTHREAD 1m & 3m</p> <p>304</p> <p>AL04PCM</p> <p>304 STAINLESS STEEL DIN 975 / A2</p>	<p>UNC ALLTHREAD 3ft</p> <p>304</p> <p>AL04PC</p> <p>304 STAINLESS STEEL IFI 136C / A2</p>	<p>BSW ALLTHREAD 3ft</p> <p>304</p> <p>AL04PW</p> <p>304 STAINLESS STEEL AS 3501 / A2</p>	<p>METRIC ALLTHREAD 1m & 3m</p> <p>316</p> <p>AL16PCM</p> <p>316 STAINLESS STEEL DIN 975 / A4</p>	<p>UNC ALLTHREAD 3ft</p> <p>316</p> <p>AL16PC</p> <p>316 STAINLESS STEEL IFI 136C / A4</p>	<p>METRIC FINE ALLTHREAD 1m</p> <p>316</p> <p>AL16PFM</p> <p>316 STAINLESS STEEL DIN 975 / A4</p>	<p>UNF ALLTHREAD 3ft</p> <p>316</p> <p>AL16PF</p> <p>316 STAINLESS STEEL IFI 136C / A4</p>
<p>BSF ALLTHREAD 3ft</p> <p>316</p> <p>AL16PS</p> <p>316 STAINLESS STEEL AS 3501 / A4</p>	<p>BSW ALLTHREAD 3ft</p> <p>316</p> <p>AL16PW</p> <p>316 STAINLESS STEEL AS 3501 / A4</p>	<p>NEW ENGINEER STUD</p> <p>316</p> <p>AES16PCM</p> <p>316 STAINLESS STEEL HEC 938 / A4</p>	<p>METRIC HEX COUPLER</p> <p>316</p> <p>AXHC16PCM</p> <p>316 STAINLESS STEEL HEC / A4</p>	<p>METRIC HEX SET SCREW</p> <p>304</p> <p>BS04PCM</p> <p>304 STAINLESS STEEL DIN 933 / A2</p>	<p>UNC HEX SET SCREW</p> <p>304</p> <p>BS04P</p> <p>304 STAINLESS STEEL ANSI B18.2.1 / A2</p>	<p>UNF HEX SET SCREW</p> <p>304</p> <p>BS04PF</p> <p>304 STAINLESS STEEL ANSI B18.2.1 / A2</p>
<p>BSW HEX SET SCREW</p> <p>304</p> <p>BS04PW</p> <p>304 STAINLESS STEEL BS 1083 / A2</p>	<p>METRIC HEX SET SCREW</p> <p>316</p> <p>BS16PCM</p> <p>316 STAINLESS STEEL DIN 933 / A4</p>	<p>UNC HEX SET SCREW</p> <p>316</p> <p>BS16PC</p> <p>316 STAINLESS STEEL ANSI B18.2.1 / A4</p>	<p>BSW HEX SET SCREW</p> <p>316</p> <p>BS16PW</p> <p>316 STAINLESS STEEL BS 1083 / A4</p>	<p>METRIC HEX BOLT</p> <p>304</p> <p>BH04PCM</p> <p>304 STAINLESS STEEL DIN 931 / A2</p>	<p>UNC HEX BOLT</p> <p>304</p> <p>BH04PC</p> <p>304 STAINLESS STEEL ANSI B18.2.1 / A2</p>	<p>UNF HEX BOLT</p> <p>304</p> <p>BH04PF</p> <p>304 STAINLESS STEEL ANSI B18.2.1 / A2</p>
<p>METRIC HEX BOLT</p> <p>316</p> <p>BH16PCM</p> <p>316 STAINLESS STEEL DIN 931 / A4</p>	<p>UNC HEX BOLT</p> <p>316</p> <p>BH16PC</p> <p>316 STAINLESS STEEL ANSI B18.2.1 / A4</p>	<p>BSW HEX BOLT</p> <p>316</p> <p>BH16PW</p> <p>316 STAINLESS STEEL BS 1083 / A4</p>	<p>HEX BOLT BLANK</p> <p>316</p> <p>BH16PBM</p> <p>316 STAINLESS STEEL DIN 931 / A4</p>	<p>METRIC CUP HEAD SQUARE</p> <p>304</p> <p>BC04PCM</p> <p>304 STAINLESS STEEL DIN 603 / A2</p>	<p>UNC CUP HEAD SQUARE</p> <p>304</p> <p>BC04PC</p> <p>304 STAINLESS STEEL ANSI B18.5 / A2</p>	<p>METRIC CUP HEAD SQUARE</p> <p>316</p> <p>BC16PCM</p> <p>316 STAINLESS STEEL DIN 603 / A4</p>



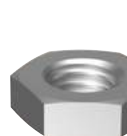
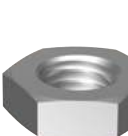
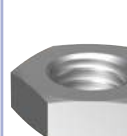
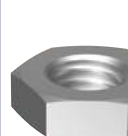









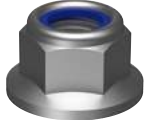

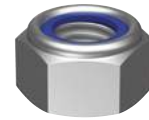
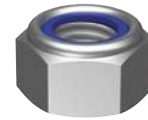
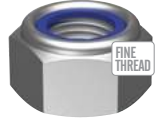
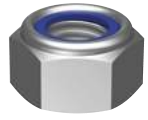
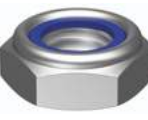
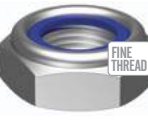
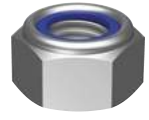
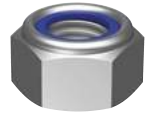
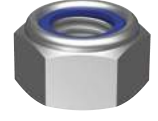

<p>NEW FLANGED HEX BOLT</p> <p>304 SERRATED</p>  <p>BF04P6CM</p> <p>304 STAINLESS STEEL DIN 6921 / A2</p>	<p>METRIC HEX COACH SCREW</p> <p>316</p>  <p>BH16PLM</p> <p>316 STAINLESS STEEL DIN 571 / A4</p>	<p>UNC DOME HEX NUT</p> <p>304</p>  <p>ND04P</p> <p>304 STAINLESS STEEL HEC / A2</p>	<p>METRIC DOME HEX NUT</p> <p>304</p>  <p>ND04PCM</p> <p>304 STAINLESS STEEL DIN 1587 / A2</p>	<p>UNF DOME HEX NUT</p> <p>304</p>  <p>ND04PF</p> <p>304 STAINLESS STEEL HEC / A2</p>	<p>METRIC DOME 2PC HEX NUT</p> <p>304</p>  <p>ND04WCM</p> <p>304 STAINLESS STEEL HEC / A2</p>	<p>BSW DOME 2PC HEX NUT</p> <p>304</p>  <p>ND04WW</p> <p>304 STAINLESS STEEL HEC / A2</p>
<p>METRIC DOME HEX NUT</p> <p>316</p>  <p>ND16PCM</p> <p>316 STAINLESS STEEL DIN 1587 / A4</p>	<p>METRIC SHEAR NUT</p> <p>304</p>  <p>NS04PCM</p> <p>304 STAINLESS STEEL HEC / A2</p>	<p>METRIC HEX FLANGE NUT</p> <p>304 SERRATED</p>  <p>NF04PCM</p> <p>304 STAINLESS STEEL ISO 4161 / A2</p>	<p>UNC HEX FLANGE NUT</p> <p>316 SERRATED</p>  <p>NF16PC</p> <p>316 STAINLESS STEEL IFI-145 / B18.2.2 / A4</p>	<p>METRIC HEX FLANGE NUT</p> <p>316 SERRATED</p>  <p>NF16PCM</p> <p>316 STAINLESS STEEL ISO 4161 / A4</p>	<p>METRIC WELD HEX NUT</p> <p>304</p>  <p>NH04WCM</p> <p>304 STAINLESS STEEL DIN 929 / A2</p>	<p>UNC HEX NUT</p> <p>304</p>  <p>NH04P</p> <p>304 STAINLESS STEEL ANSI B18.2.2 / A2</p>
<p>METRIC HEX NUT</p> <p>304</p>  <p>NH04PCM</p> <p>304 STAINLESS STEEL DIN 934 / A2</p>	<p>UNF HEX NUT</p> <p>304</p>  <p>NH04PF</p> <p>304 STAINLESS STEEL ANSI B18.2.2 / A2</p>	<p>METRIC FINE HEX NUT</p> <p>304</p>  <p>NH04PFM</p> <p>304 STAINLESS STEEL DIN 934 / A2</p>	<p>BSW HEX NUT</p> <p>304</p>  <p>NH04PW</p> <p>304 STAINLESS STEEL BS 1083 / A2</p>	<p>UNC HEX NUT</p> <p>316</p>  <p>NH16P</p> <p>316 STAINLESS STEEL ANSI B18.2.2 / A4</p>	<p>METRIC HEX NUT</p> <p>316</p>  <p>NH16PCM</p> <p>316 STAINLESS STEEL DIN 934 / A4</p>	<p>METRIC LEFT HAND HEX NUT</p> <p>316</p>  <p>NH16PDM</p> <p>316 STAINLESS STEEL DIN 934 / A4</p>
<p>UNF HEX NUT</p> <p>316</p>  <p>NH16PF</p> <p>316 STAINLESS STEEL ANSI B18.2.2 / A4</p>	<p>NEW METRIC FINE HEX NUT</p> <p>316</p>  <p>NH16PFM</p> <p>316 STAINLESS STEEL DIN 934 / A4</p>	<p>BSW HEX NUT</p> <p>316</p>  <p>NH16PW</p> <p>316 STAINLESS STEEL B18.6.3 / A4</p>	<p>UNC THIN HEX LOCK NUT</p> <p>304</p>  <p>NL04PC</p> <p>304 STAINLESS STEEL ANSI B18.2.2 / A2</p>	<p>METRIC THIN HEX LOCK NUT</p> <p>304</p>  <p>NL04PCM</p> <p>304 STAINLESS STEEL DIN 439 / A2</p>	<p>UNC THIN HEX LOCK NUT</p> <p>316</p>  <p>NL16PC</p> <p>316 STAINLESS STEEL ANSI B18.2.2 / A4</p>	<p>METRIC THIN HEX LOCK NUT</p> <p>316</p>  <p>NL16PCM</p> <p>316 STAINLESS STEEL DIN 439 / A4</p>

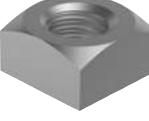

STAINLESS FASTENERS

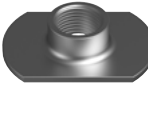
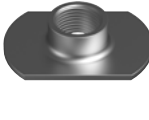

<p>UNF THIN HEX LOCK NUT</p> <p>316</p>  <p>NL16PF</p> <p>316 STAINLESS STEEL ANSI B18.2.2 / A4</p>	<p>METRIC HEX NUT</p> <p>316</p>  <p>NH16LCM</p> <p>1PX1 MOLY / 316 STAINLESS STEEL DIN 934 / A4</p>	<p>NEW HEX FLANGE NUT NYLOC</p> <p>304 NO SERRATIONS</p>  <p>NF04PNNCM</p> <p>304 STAINLESS STEEL DIN 6926 / A2</p>	<p>NYLOC®</p> <p>The special nylon insert prevents loosening caused by vibration.</p> 	<p>UNC HEX NUT NYLOC</p> <p>304</p>  <p>NN04P</p> <p>304 STAINLESS STEEL IFI-100/107 / A2</p>	<p>METRIC HEX NUT NYLOC</p> <p>304</p>  <p>NN04PCM</p> <p>304 STAINLESS STEEL DIN 985 / A2</p>
<p>UNF HEX NUT NYLOC</p> <p>304</p>  <p>NN04PF</p> <p>304 STAINLESS STEEL HEC / A2</p>	<p>BSW HEX NUT NYLOC</p> <p>304</p>  <p>NN04PW</p> <p>304 STAINLESS STEEL HEC / A2</p>	<p>UNC THIN HEX NUT NYLOC</p> <p>304</p>  <p>NN04TC</p> <p>304 STAINLESS STEEL HEC / A2</p>	<p>UNF THIN HEX NUT NYLOC</p> <p>304</p>  <p>NN04TF</p> <p>304 STAINLESS STEEL HEC / A2</p>	<p>UNC HEX NUT NYLOC</p> <p>316</p>  <p>NN16P</p> <p>316 STAINLESS STEEL IFI-100/107 / A4</p>	<p>METRIC HEX NUT NYLOC</p> <p>316</p>  <p>NN16PCM</p> <p>316 STAINLESS STEEL DIN 985 / A4</p>
<p>BSW HEX NUT NYLOC</p> <p>316</p>  <p>NN16PW</p> <p>316 STAINLESS STEEL HEC / A4</p>	<p>METRIC HEX NUT HOBLOCH™</p> <p>304</p>  <p>NN04HCM</p> <p>304 STAINLESS STEEL DIN980 TYPE M / A2</p>	<p>METRIC FINE HEX NUT HOBLOCH™</p> <p>304</p>  <p>NN04HFM</p> <p>304 STAINLESS STEEL HEC / A2</p>	<p>BSW HEX NUT HOBLOCH™</p> <p>304</p>  <p>NN04HW</p> <p>304 STAINLESS STEEL HEC / A2</p>	<p>METRIC SQUARE NUT</p> <p>316</p>  <p>NQ16PCM</p> <p>316 STAINLESS STEEL DIN 557 / A4</p>	<p>UNC WING NUT</p> <p>304</p>  <p>NW04P</p> <p>304 STAINLESS STEEL ANSI B18.17 / A2</p>
<p>UNC WING NUT</p> <p>316</p>  <p>NW16P</p> <p>316 STAINLESS STEEL ANSI B18.17 / A4</p>	<p>METRIC WING NUT</p> <p>316</p>  <p>NW16PCM</p> <p>316 STAINLESS STEEL ANSI B18.17 / A4</p>	<p>BSW WING NUT</p> <p>316</p>  <p>NW16PW</p> <p>316 STAINLESS STEEL ANSI B18.17 / A4</p>	<p>NEW SLAB TYPE TEE NUT</p> <p>304</p>  <p>NT04PSC</p> <p>304 STAINLESS STEEL HEC / A2</p>	<p>NEW METRIC SLAB TYPE TEE NUT</p> <p>304</p>  <p>NT04PSCM</p> <p>304 STAINLESS STEEL HEC / A2</p>	<p>Tee Nut</p> <p>Large base flange for soft materials eliminates the need for a washer.</p> 



**STAINLESS
FASTENERS**

NYLOC[®]

Anti-vibration solution















**Nylon
Insert
Locknuts**



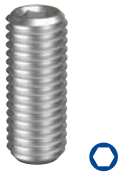

STAINLESS FASTENERS

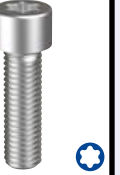

<p>UNC BUTTON HEAD HEX SOCKET</p> <p>304</p>  <p>SB04P</p> <p>304 STAINLESS STEEL ANSI B18.3/A2</p>	<p>METRIC BUTTON HEAD HEX SOCKET</p> <p>304</p>  <p>SB04PCM</p> <p>304 STAINLESS STEEL ISO 7380/A2</p>	<p>METRIC BUTTON HEAD TORX SOCKET</p> <p>304</p>  <p>SB04POCM</p> <p>304 STAINLESS STEEL ISO 7380/A2</p>	<p>METRIC BUTTON HEAD HEX SOCKET</p> <p>316</p>  <p>SB16PCM</p> <p>316 STAINLESS STEEL ISO 7380/A4</p>	<p>UNC CSK FLAT HEX SOCKET</p> <p>304</p>  <p>SC04P</p> <p>304 STAINLESS STEEL ANSI B18.3/A2</p>	<p>METRIC CSK FLAT HEX SOCKET</p> <p>304</p>  <p>SC04PCM</p> <p>304 STAINLESS STEEL ISO 10642/A2</p>	<p>METRIC CSK FLAT TORX SOCKET</p> <p>304</p>  <p>SC04POCM</p> <p>304 STAINLESS STEEL HEC 10642/A2</p>
<p>METRIC CSK FLAT HEX SOCKET</p> <p>316</p>  <p>SC16PCM</p> <p>316 STAINLESS STEEL ISO 10642/A4</p>	<p>NEW METRIC CSK FLAT HEX SOCKET</p> <p>316</p>  <p>SC16PCM24</p> <p>316 STAINLESS STEEL DIN 7991/A4</p>	<p>UNC CUP POINT HEX SOCKET</p> <p>304</p>  <p>SG04P</p> <p>304 STAINLESS STEEL ANSI B18.3/A2</p>	<p>METRIC CUP POINT HEX SOCKET</p> <p>304</p>  <p>SG04PCM</p> <p>304 STAINLESS STEEL DIN 916/A2</p>	<p>UNC CAP SCREW HEX SOCKET</p> <p>304</p>  <p>SH04P</p> <p>304 STAINLESS STEEL ANSI B18.3/1960/A2</p>	<p>METRIC CAP SCREW HEX SOCKET</p> <p>304</p>  <p>SH04PCM</p> <p>304 STAINLESS STEEL DIN 912/A2</p>	<p>NEW METRIC CAP SCREW TORX SOCKET</p> <p>304</p>  <p>SH04POCM</p> <p>304 STAINLESS STEEL ISO 14579/A2</p>

Machine Screw Head types



**BUTTON
HEAD**



**MUSHROOM
HEAD**



**ROUND
HEAD**



**COUNTERSUNK
HEAD**



**WING
HEAD**



**PAN
HEAD**



**CHEESE
HEAD**



**SOCKET HEAD
CAP SCREW**



**LOW HEAD
CAP SCREW**



UNC CAP SCREW HEX SOCKET

316

SH16PC

316
STAINLESS STEEL
ANSI B18.3/1960 / A4

METRIC CAP SCREW HEX SOCKET

316

SH16PCM

316
STAINLESS STEEL
DIN 912 / A4

METRIC LOW HEAD HEX SOCKET

304

SL04PCM

304
STAINLESS STEEL
DIN 7984 / A2

UNC CSK HEAD PHILLIPS

304

MS04CP

304
STAINLESS STEEL
ANSI B18.6.3 / A2

METRIC CSK HEAD PHILLIPS

304

MS04CPM

304
STAINLESS STEEL
DIN 965 (H) / A2

BSW CSK HEAD PHILLIPS

304

MS04CPW

304
STAINLESS STEEL
BS 450 / A2

UNF CSK HEAD PHILLIPS

304

MS04CPF

304
STAINLESS STEEL
ANSI B18.6.3 / A2

METRIC CSK HEAD PHILLIPS

316

MS16CPM

316
STAINLESS STEEL
DIN 965 (H) / A4

BSW CSK HEAD PHILLIPS

316

MS16CPW

316
STAINLESS STEEL
BS 450 / A4

METRIC CSK HEAD SLOTTED

304

MS04CSM

304
STAINLESS STEEL
DIN 963 / A2

METRIC CSK HEAD SLOTTED

316

MS16CSM

316
STAINLESS STEEL
DIN 963 / A4

METRIC CHEESE HEAD SLOTTED

304

MS04ESM

304
STAINLESS STEEL
DIN 84 / A2

METRIC CHEESE HEAD SLOTTED

316

MS16ESM

316
STAINLESS STEEL
DIN 84 / A4

UNC PAN HEAD PHILLIPS

304

MS04PP

304
STAINLESS STEEL
ANSI B18.6.3 / A2

METRIC PAN HEAD PHILLIPS

304

MS04PPM

304
STAINLESS STEEL
DIN 7985 (H) / A2

BSW PAN HEAD PHILLIPS

304

MS04PPW

304
STAINLESS STEEL
BS 450 / A2

UNF PAN HEAD PHILLIPS

304

MS04PPF

304
STAINLESS STEEL
ANSI B18.6.3 / A2

METRIC PAN HEAD PHILLIPS

316

MS16PPM

316
STAINLESS STEEL
DIN 7985 (H) / A4

BSW PAN HEAD PHILLIPS

316

MS16PPW

316
STAINLESS STEEL
BS 450 / A4

BSW ROUND HEAD SLOTTED

304

MS04OSW

304
STAINLESS STEEL
BS 450 / A2

BSW ROUND HEAD SLOTTED

316

MS16OSW

316
STAINLESS STEEL
BS 450 / A4

METRIC MUSHROOM PHILLIPS

304

MS04MPM

304
STAINLESS STEEL
AS 1427 / A2

BSW MUSHROOM PHILLIPS

304

MS04MPW

304
STAINLESS STEEL
BS 450 / A2

NEW METAL THREAD WING SCREW

304

MS04PWM

304
STAINLESS STEEL
DIN 316B / A2

Wing Screw

Distinctive wings extending from the head that enable easy tightening and removal without the use of a tool.





STAINLESS FASTENERS



<p>SELF-TAPPING CSK HEAD PHILLIPS</p> <p>304</p> <p>T04SSCP</p> <p>304 STAINLESS STEEL ANSI B18.6.4 / A2</p>	<p>SELF-TAPPING CSK HEAD SQUARE DR</p> <p>304</p> <p>T04SSCQ</p> <p>304 STAINLESS STEEL ANSI B18.6.4 / A2</p>	<p>SELF-TAPPING CSK HEAD PHILLIPS</p> <p>316</p> <p>T16SSCP</p> <p>316 STAINLESS STEEL ANSI B18.6.4 / A4</p>	<p>SELF-TAPPING UNDERCUT CSK PHILLIPS</p> <p>304</p> <p>T04SSDP</p> <p>304 STAINLESS STEEL ANSI B18.6.4 / A2</p>	<p>SELF-TAPPING UNDERCUT CSK PHILLIPS</p> <p>410</p> <p>T41SSDP</p> <p>410 STAINLESS STEEL ANSI B18.6.4</p>	<p>SELF-TAPPING UNDERCUT CSK SQUARE DR</p> <p>304</p> <p>T04SSDQ</p> <p>304 STAINLESS STEEL ANSI B18.6.4 / A2</p>	<p>SELF-TAPPING PAN HEAD PHILLIPS</p> <p>304</p> <p>T04SSPP</p> <p>304 STAINLESS STEEL ANSI B18.6.4 / A2</p>
<p>SELF-TAPPING PAN HEAD SQUARE DR</p> <p>304</p> <p>T04SSPQ</p> <p>304 STAINLESS STEEL ANSI B18.6.4 / A2</p>	<p>SELF-TAPPING PAN HEAD PHILLIPS</p> <p>316</p> <p>T16SSPP</p> <p>316 STAINLESS STEEL ANSI B18.6.4 / A4</p>	<p>SELF-TAPPING PAN PHILLIPS PILOT POINT</p> <p>410</p> <p>T41PSP</p> <p>410 STAINLESS STEEL ANSI B18.6.4</p>	<p>SELF-TAPPING PAN SQUARE PILOT POINT</p> <p>410</p> <p>T41PSPQ</p> <p>410 STAINLESS STEEL ANSI B18.6.4</p>	<p>Pilot Point</p> <p>The Pilot Point fits in a pre-drilled pilot (or guiding) hole and helps speed alignment during automated assembly.</p>		<p>SELF-TAPPING RAISED HEAD ONE WAY</p> <p>304</p> <p>I04SSRO</p> <p>304 STAINLESS STEEL SECURITY / A2</p>
<p>WOOD SCREW CSK HEAD PHILLIPS</p> <p>304</p> <p>T04DSCP</p> <p>304 STAINLESS STEEL JIS B1112 / A2</p>	<p>NEW COACH SCREW CSK HEAD HEX SOCKET</p> <p>316</p> <p>SC16PLM</p> <p>316 STAINLESS STEEL HEC / A4</p>	<p>SPRING WAVE PIN</p> <p>QPW20PM</p> <p>420 STAINLESS STEEL JIS B 2808:1999</p>	<p>METRIC SPLIT PIN</p> <p>304</p> <p>QPS04PM</p> <p>304 STAINLESS STEEL DIN 94 / A2</p>	<p>METRIC SPLIT PIN</p> <p>316</p> <p>QPS16PM</p> <p>316 STAINLESS STEEL DIN 94 / A4</p>	<p>SECURITY SOCKET KEY POST HEX</p> <p>ISKPH</p> <p>PLN SECURITY HEC</p>	<p>SECURITY SOCKET KEY POST TORX</p> <p>ISKPT</p> <p>PLN SECURITY HEC</p>
<p>TYPE U DRIVE SCREW</p> <p>304</p> <p>QDS04RU</p> <p>304 STAINLESS STEEL ANSI B18.6.4 / A2</p>	<p>LINCH PIN</p> <p>316</p> <p>QPL16PM</p> <p>316 STAINLESS STEEL HEC / A4</p>					



Security Screw Solutions

<p>SECURITY SOCKET BIT POST TORX</p>  <p>ISBPT PLN SECURITY HEC</p>		<p>SECURITY SOCKET BIT POST HEX</p>  <p>ISBPH PLN SECURITY HEC</p>		<p>SECURITY SOCKET BIT EYE DRIVE</p>  <p>ISBED PLN SECURITY HEC</p>		
<p>NEW SDS BUTTON POST TORX</p>  <p>I41MSBT 410 STAINLESS STEEL HEC</p>	<p>SELF-TAPPING SKT BUTTON POST TORX</p>  <p>I04SSBT 304 STAINLESS STEEL SECURITY /A2</p>	<p>METRIC SKT BUTTON POST TORX</p>  <p>IMS04BTM 304 STAINLESS STEEL SECURITY /A2</p>	<p>UNC SKT BUTTON POST TORX</p>  <p>IMS04BTC 304 STAINLESS STEEL SECURITY /A2</p>	<p>BARREL NUT BUTTON POST TORX</p>  <p>INB04BTM 304 STAINLESS STEEL SECURITY /A2</p>	<p>SELF-TAPPING CSK SOCKET POST TORX</p>  <p>I04SSCT 304 STAINLESS STEEL SECURITY /A2</p>	<p>METRIC CSK SOCKET POST TORX</p>  <p>IMS04CTM 304 STAINLESS STEEL SECURITY /A2</p>
<p>METRIC SKT BUTTON POST HEX</p>  <p>IMS04BHM 304 STAINLESS STEEL SECURITY /A2</p>	<p>METRIC CSK SOCKET POST HEX</p>  <p>IMS04CHM 304 STAINLESS STEEL SECURITY /A2</p>	<p>SELF-TAPPING CSK SOCKET POST HEX</p>  <p>I04SSCH 304 STAINLESS STEEL SECURITY /A2</p>	<p>METRIC PAN HEAD EYE DRIVE</p>  <p>IMS04PEM 304 STAINLESS STEEL SECURITY /A2</p>	<p>METRIC CSK HEAD EYE DRIVE</p>  <p>IMS04CEM 304 STAINLESS STEEL SECURITY /A2</p>	<p>SELF-TAPPING CSK HEAD EYE DRIVE</p>  <p>I04SSCE 304 STAINLESS STEEL SECURITY /A2</p>	<p>SELF-TAPPING PAN HEAD EYE DRIVE</p>  <p>I04SSPE 304 STAINLESS STEEL SECURITY /A2</p>

WASHERS







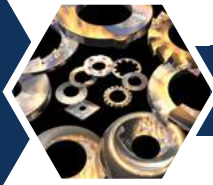





















WASHERS



WASHERS



METRIC ENGINEERS WASHER	METRIC FLAT ROUND WASHER	METRIC FLAT ROUND WASHER	METRIC FLAT ROUND WASHER	NEW METRIC FLAT ROUND WASHER	METRIC FLAT ROUND WASHER	KEY BRASS BRASS PLN PLAIN Z/P ZINC PLATED (RoHS COMPLIANT) ZYP ZINC YELLOW PASSIVATE ZPB ZINC BLACK PASSIVATE HDG HOT DIP GALVANISED ZFS ZINC FLAKE SILVER RED FIB RED FIBRE XYB XYLAN BLUE
						
WEMSZM	WRMSGM	WRMSZM	WRMSYM	WRMSVM	WRMSPM	
Z/P AS 1237:1973 MILD STEEL	HDG HEC MILD STEEL	Z/P HEC MILD STEEL	ZYP DIN 125A MILD STEEL	ZBP HEC MILD STEEL	PLN HEC MILD STEEL	
						
WRMSZ	WR04PM	WR04TM	WR04P	WR16PM	WR16TM	
Z/P HEC MILD STEEL	304 STAINLESS STEEL HEC / A2	304 STAINLESS STEEL DIN 125A / A2	304 STAINLESS STEEL HEC / A2	316 STAINLESS STEEL HEC / A4	316 STAINLESS STEEL DIN 125A / A4	
						
WR16P	WXMSGM	WXMSZM	WRMSZLM	WRMSPLM	WRMSGLM	
316 STAINLESS STEEL HEC / A4	HDG AS 1237.1-2002 MILD STEEL	Z/P AS 1237.1-2002 MILD STEEL	Z/P HEC MILD STEEL	PLN HEC MILD STEEL	HDG HEC MILD STEEL	
						
WRMSZU	WR04MM	WR16MM	WX16PLM	WR04PU	WRBRP	WRBRPM
Z/P HEC MILD STEEL	304 STAINLESS STEEL DIN 9021 / A2	316 STAINLESS STEEL DIN 9021 / A4	316 STAINLESS STEEL HEC / A4	304 STAINLESS STEEL HEC / A2	BRASS HEC BS 3410	BRASS HEC AS 1237



<p>METRIC SPRING FLAT SECTION</p> <p>304</p> <p>WR04SM</p> <p>304 STAINLESS STEEL HEC 127B</p>	<p>IMPERIAL SPRING FLAT SECTION</p> <p>304</p> <p>WR04S0</p> <p>304 STAINLESS STEEL ANSI B18.21.1</p>	<p>IMPERIAL SPRING FLAT SECTION</p> <p>316</p> <p>WR16S</p> <p>316 STAINLESS STEEL ANSI B18.21.1</p>	<p>METRIC SPRING FLAT SECTION</p> <p>316</p> <p>WR16SM</p> <p>316 STAINLESS STEEL HEC 127B/A4</p>	<p>METRIC SPRING FLAT SECTION</p> <p>WRMSGSM</p> <p>HDG HEC 127B SPRING STEEL</p>	<p>METRIC SPRING FLAT SECTION</p> <p>WRMSZSM</p> <p>Z/P HEC 127B SPRING STEEL</p>	<p>METRIC SPRING FLAT SECTION</p> <p>WRMSYSM</p> <p>ZYP HEC 127B SPRING STEEL</p>
<p>IMPERIAL SPRING FLAT SECTION</p> <p>WRMSZS</p> <p>Z/P ANSI B18.21.1 SPRING STEEL</p>	<p>METRIC SPRING SQ SECTION</p> <p>WRMSZSQM</p> <p>Z/P HEC 7980 SPRING STEEL</p>	<p>METRIC SPRING SQ SECTION</p> <p>WRMSYSQM</p> <p>ZYP HEC 7980 SPRING STEEL</p>	<p>IMPERIAL SPRING SQ SECTION</p> <p>WRMSGSQ</p> <p>HDG ANSI B18.21.1 SPRING STEEL</p>	<p>IMPERIAL SPRING SQ SECTION</p> <p>WRMSZSQ</p> <p>ZYP ANSI B18.21.1 SPRING STEEL</p>	<p>Spring Washer</p> <p>Prevents loosening of bolted assemblies under vibration.</p> <p>→ Square section</p>	

Washer types

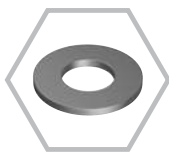

STANDARD WASHERS

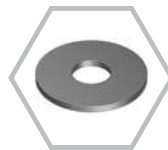

LARGE OD WASHERS

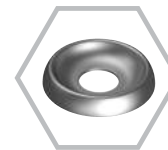

CUP WASHERS

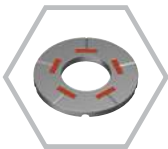

SQUIRTER WASHERS (DTI)



SPRING WASHERS



LOCK WASHERS



LOAD INDICATING WASHERS (LIW)

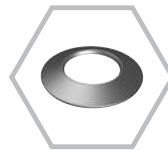

BELLEVILLE WASHERS

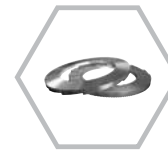

LOCK WASHERS 2 PIECE TYPE (NORD-LOCK®)



STRUCTURAL WASHERS



SAFETY WASHERS

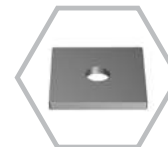















SQUARE WASHERS



WASHERS



<p>LOCK INTERNAL TOOTH</p>  <p>WLMSZTIM</p> <p>Z/P IFI 532 TYPE A</p>	<p>LOCK EXTERNAL TOOTH</p>  <p>WLMSZTEM</p> <p>Z/P IFI 532 TYPE A</p>	<p>LOCK INTERNAL TOOTH</p>  <p>WLMSZTI</p> <p>Z/P ASME B18.21.1 TYPE A</p>	<p>LOCK EXTERNAL TOOTH</p>  <p>WLMSZTE</p> <p>Z/P ASME B18.21.1 TYPE A</p>	<p>LOCK EXTERNAL TOOTH</p> <p>304</p>  <p>WL04TEM</p> <p>304 STAINLESS STEEL DIN 6797 / TYPE A</p>	<p>LOCK INTERNAL TOOTH</p> <p>304</p>  <p>WL04TIM</p> <p>304 STAINLESS STEEL DIN 6797 / TYPE J</p>	<p>LOCK EXTERNAL SERR TOOTH</p> <p>316</p>  <p>WL16SEM</p> <p>316 STAINLESS STEEL DIN 6798 / TYPE A</p>
<p>LOCK EXTERNAL SERR TOOTH</p> <p>304</p>  <p>WL04SEM</p> <p>304 STAINLESS STEEL DIN 6798 / TYPE A</p>	<p>LOCK INTERNAL SERR TOOTH</p> <p>304</p>  <p>WL04SIM</p> <p>304 STAINLESS STEEL DIN 6798 / TYPE J</p>	<p>CUP WASHER</p> <p>304</p>  <p>WR04C</p> <p>304 STAINLESS STEEL HEC / A2</p>	<p>METRIC BELLEVILLE WASHER</p> <p>304</p>  <p>WR04BM</p> <p>304 STAINLESS STEEL HEC 2093A / A2</p>	<p>METRIC FLAT ROUND WASHER</p>  <p>WRRFPM</p> <p>RED FIBRE HEC</p>	<p>METRIC SQUARE WASHER</p> <p>316</p>  <p>WS16PM</p> <p>316 STAINLESS STEEL HEC / A4</p>	<p>METRIC SQUARE WASHER</p>  <p>WSMSGM</p> <p>HDG HEC MILD STEEL</p>

For more washers check out:

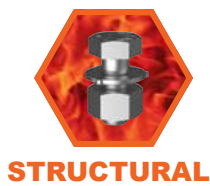

<p>METRIC SQUARE WASHER</p>  <p>WSMSYM</p> <p>ZYP HEC MILD STEEL</p>
<p>SQUARE WASHER SQUARE HOLE</p>  <p>WSMSGQ</p> <p>HDG HEC MILD STEEL</p>

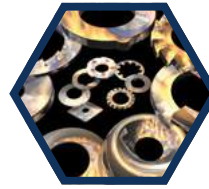

<p>METRIC SQUARE WASHER</p>  <p>WSMSPM PLN HEC MILD STEEL</p>	<p>METRIC SQUARE WASHER</p>  <p>WSMSZM Z/P HEC MILD STEEL</p>	<p>METRIC SQUARE WASHER</p> <p>HARDENED</p>  <p>WSHTGM HDG HEC 35-41 HRC</p>	<p>Hardened Washers</p> <p>Hardness 35-41 HRC</p> 		<p>METRIC FLAT ROUND WASHER</p> <p>HARDENED</p>  <p>WRHTGM HDG AS1237 35-41 HRC</p>	<p>NEW METRIC FLAT ROUND WASHER</p> <p>HARDENED</p>  <p>WRV3FM ZFS ISO 7089 300 HV</p>
<p>METRIC FLAT ROUND SAMPSON™</p> <p>SAMPSON™</p>  <p>WR43PM PLN HEC 38-45 HRC</p>	<p>METRIC FLAT ROUND SAMPSON™</p> <p>SAMPSON™</p>  <p>WR43ZM Z/P ASTM F436M 38-45 HRC</p>	<p>IMPERIAL FLAT ROUND SAMPSON™</p> <p>SAMPSON™</p>  <p>WR43P PLN ASTM F436 38-45 HRC</p>	<p>NEW IMPERIAL FLAT ROUND SAMPSON™</p> <p>SAMPSON™</p>  <p>WR43Z Z/P ASTM F436 38-45 HRC</p>	<p>IMPERIAL FLAT ROUND SAMPSON™</p> <p>SAMPSON™</p>  <p>WR43Y ZYP ASTM F436 38-45 HRC</p>	<p>IMPERIAL FLAT ROUND SAMPSON™</p> <p>SAMPSON™</p>  <p>WR43B XYB ASTM F436 38-45 HRC</p>	<p>METRIC FLAT ROUND SAMPSON™</p> <p>SAMPSON™</p>  <p>WR43FM ZFS ASTM F436M 38-45 HRC</p>
<p>IMPERIAL FLAT ROUND H9 IMPACT™</p> <p>H9 IMPACT™</p>  <p>WRH9P PLN HEC 43-49 HRC</p>	<p>IMPERIAL FLAT ROUND H9 IMPACT™</p> <p>H9 IMPACT™</p>  <p>WRH9Y ZYP HEC 43-49 HRC</p>	<p>H9 IMPACT™</p> <p>Hardness 43-49 HRC</p> 		<p>FISHBOLT SPRING WASHER</p>  <p>DWRHTPSM PLN AS 1085.7</p>	<p>NEW METRIC SECURITY MESH CLIP</p> <p>316</p>  <p>HWC16PM 316 STAINLESS STEEL HEC / A4</p>	<p>METRIC SECURITY MESH CLIP</p>  <p>HWCMSGM HDG HEC MILD STEEL</p>
<p>VOLUTE SPRING WASHER</p> <p>316</p>  <p>WV16PM 316 STAINLESS STEEL AS 2837 / A4</p>	<p>SKID PLATE CUP WASHER</p> <p>304</p>  <p>WR04KM 304 STAINLESS STEEL HEC / A2</p>	<p>NEW SQUARE WASHER XBolt</p>  <p>WSMSGX HDG HEC MILD STEEL</p>	<p>NEW SQUARE WASHER XBolt</p>  <p>WSMSYX ZYP HEC MILD STEEL</p>	<p>Square Washer XBolt</p>  <p>Specifically suited for XBolt® Screw Bolts as their oversized holes allow them to fit over the larger XBolt® threads.</p>		

Build **Anything**



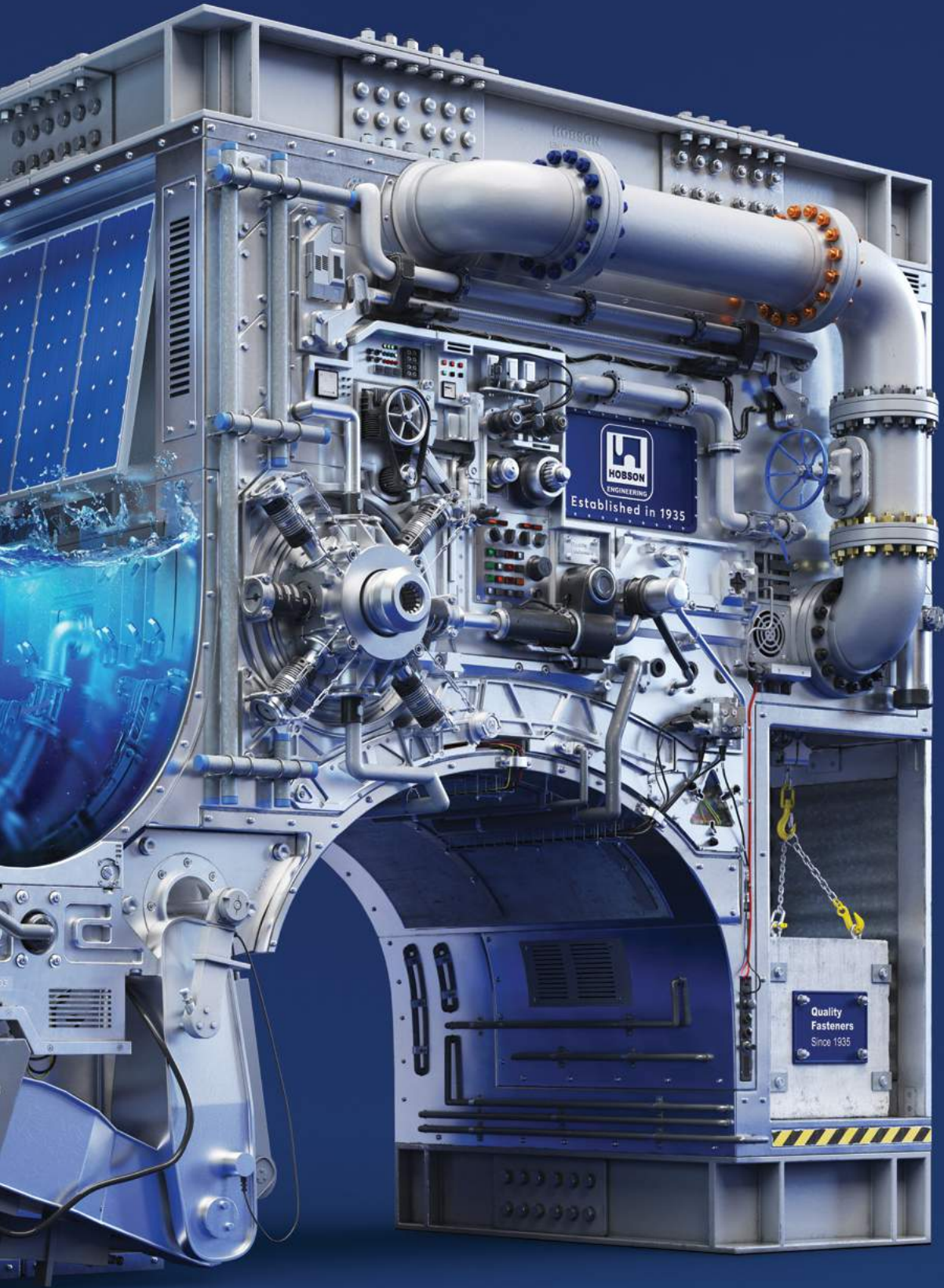

Z

O

L

X

Z



NYLON



NYLON



POLYAMIDE PA6, PA6.6, 66

Natural Nylon

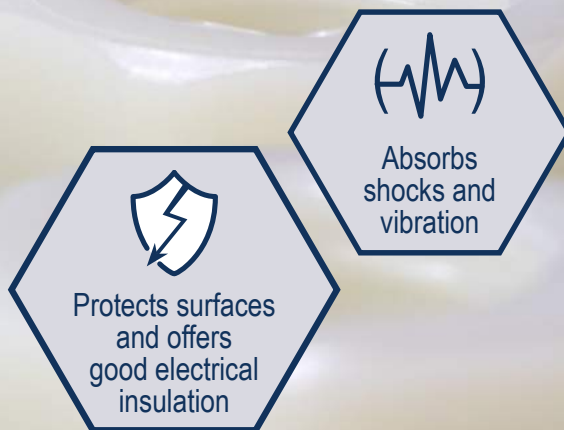

<p>UNC HEX SET SCREW</p>  <p>BS66PC</p> <p>NYLN ASME B18.2.1 HEC</p>	<p>METRIC HEX SET SCREW</p>  <p>BS66PCM</p> <p>NYLN DIN 933</p>	<p>UNC HEX BOLT</p>  <p>BH66PC</p> <p>NYLN HEC</p>	<p>METRIC HEX BOLT</p>  <p>BH66PCM</p> <p>NYLN DIN 931</p>	<p>UNC CSK SLOT SCREW</p>  <p>MS66CS</p> <p>NYLN HEC</p>	<p>METRIC CSK SLOT SCREW</p>  <p>MS66CSM</p> <p>NYLN DIN 963</p>	<p>METRIC CHEESE SLOT SCREW</p>  <p>MS66ESM</p> <p>NYLN DIN 84</p>
<p>UNC ROUND SLOT SCREW</p>  <p>MS66OS</p> <p>NYLN HEC</p>	<p>UNC SLOT FILLISTER SCREW</p>  <p>MS66LS</p> <p>NYLN HEC</p>	<p>METRIC WING SCREW</p>  <p>MS66PWM</p> <p>NYLN DIN 316</p>	<p>BINDER HEAD PHILLIPS SCREW</p>  <p>MS66BPM</p> <p>NYLN DIN 7985</p>	<p>UNC HEX SOCKET GRUB SCREW</p>  <p>SG66PC</p> <p>NYLN HEC</p>	<p>METRIC HEX SOCKET GRUB SCREW</p>  <p>SG66PCM</p> <p>NYLN DIN 913</p>	<p>SLOTTED SOCKET GRUB SCREW</p>  <p>SG66PSM</p> <p>NYLN DIN 551</p>



RESISTANCE CHART

Material / Substances	PA6 6.6 / 66 Polyamide Nylon	PC Polycarbonate	PVDF Polyvinylidene Fluoride	PP Polypropylene	POM Acetal	PE - LD Polyethylene Low-density	PE - HD Polyethylene High-density
Cold water	Good	Good	Good	Good	Good	Good	Good
Hot water	Limited	Limited	Good	Good	Good	Limited	Good
Diluted acid	Good	Good	Good	Good	Limited	Good	Good
Concentrated acid	Good	Limited	Limited	Limited	Good	Limited	Good
Oxidised acid	Good	Limited	Good	Good	Good	Good	Good
Hydrofluoric acids	Good	Limited	Good	Limited	Good	Limited	Limited
Diluted potassium	Good	Good	Good	Good	Good	Good	Good
Concentrated potassium	Limited	Good	Limited	Good	Good	Good	Good
Inorganic bases	Good	Good	Good	Good	Good	Good	Good
Dry halogen	Good	Good	Good	Limited	Good	Good	Good
Hydrocarbons	Good	Good	Good	Good	Good	Good	Good
Hydrocarbons (chlorinated)	Limited	Good	Good	Good	Good	Good	Limited
Alcohols	Good	Good	Good	Good	Good	Limited	Good
Ester	Good	Limited	Good	Limited	Good	Limited	Good
Ketone	Good	Limited	Good	Limited	Limited	Limited	Good
Ether	Good	Good	Good	Good	Good	Good	Limited
Aldehyde	Limited	Good	Limited	Good	Limited	Limited	Limited
Amino acids	Good	Good	Good	Good	Limited	Good	Good
Organic acids	Limited	Limited	Good	Limited	Good	Good	Good
Aromatic hydrocarbons	Good	Good	Good	Limited	Limited	Good	Limited
Petrol	Good	Limited	Good	Limited	Good	Good	Limited
Mineral oils	Good	Good	Good	Good	Good	Limited	Good
Greases and oils	Good	Good	Good	Good	Good	Good	Good
Hydrocarbons (non-saturated chlorinated)	Limited	Good	Good	Good	Good	Good	Good
Oil of turpentine	Limited	Good	Good	Good	Limited	Good	Good
Humidity absorption % to ASTM d 570	1.3 - 1.9	0.1 - 0.2	0.03	0.01 - 0.03	0.22 - 0.25	< 0.01	< 0.01

 Good Resistance

 Limited Resistance

 No Resistant



NYLON



METRIC SOCKET HEAD CAP SCREW	UNC ALLTHREAD ROD	METRIC ALLTHREAD ROD	UNC HEX NUT	METRIC HEX NUT	UNC WING NUT	KEY
						NYLN NYLON NATURAL
SH66PCM	AN66PC	AN66PCM	NH66P	NH66PCM	NW66PC	PE UV POLYETHYLENE BLK UV RESISTANT
NYLN DIN 912	NYLN HEC	NYLN DIN 975	NYLN HEC	NYLN DIN 934	NYLN HEC	NY UV NYLON BLACK
METRIC WING NUT	UNC DOME HEX NUT	UNC DOME HEX NUT	METRIC DOME HEX NUT	METRIC DOME HEX NUT	METRIC HEX FLANGE NUT	SPACER ROUND
						
NW66PCM	ND66P	ND66PC	ND66PCM	ND66PAM	NF66PCM	SR66P
NYLN DIN 315	NYLN HEC	NYLN HEC	NYLN DIN 1587	NYLN Form A	NYLN HEC	NYLN HEC
METRIC SCREW INSULATOR	METRIC ANTI-LOSS WASHER	METRIC CUP WASHER	METRIC HUBO™ WASHER	IMPERIAL FLAT ROUND WASHER	METRIC FLAT ROUND WASHER	METRIC FLAT ROUND WASHER
						
WB66PIM	WR66PAM	WR66PCM	WR66PHM	WR66P	WR66PM	WR66PTM
NYLN HEC	NYLN FLAT ROUND + TAPER	NYLN HEC	NYLN LOCKING + SEALING	NYLN HEC	NYLN HEC	NYLN DIN 125
METRIC MUDGUARD WASHER	METRIC HOLDING WASHER	METRIC BUSHING WASHER	METRIC FLAT ADHESIVE WASHER	<h2>Adhesive Washer</h2>  <p>Adhesive secures the washer's position and keeps it from moving around.</p>		
						
WR66PMM	WR66POM	WB66PSM	WR66PDM			
NYLN DIN 9021	NYLN HEC	NYLN WITH SHOULDER	NYLN HEC			



NYLON 66 BLACK UV STABLE WITH

Carbon Black



Improves resistance to UV and external weathering

<p>METRIC FINISHING WASHER RCC</p>  <p>WR66UCM</p> <p>NY UV UV STABLE HEC</p>	<p>METRIC MUDGUARD WASHER</p>  <p>WR66UMM</p> <p>NY UV UV STABLE DIN 9021</p>	<p>METRIC FLAT ROUND WASHER</p>  <p>WR66UM</p> <p>NY UV UV STABLE HEC</p>	<p>ROUND SPACER</p>  <p>SR66U</p> <p>NY UV UV STABLE HEC</p>
<p>METRIC HEX THIN NUT</p>  <p>NL66UCM</p> <p>NY UV UV STABLE HEC</p>	<p>PLUG HEAD COVER FOR HEX SCREW</p>  <p>PHCPEUM</p> <p>PE UV HEC / SUIT AS1110</p>	<p>Plug Head Cover</p> <p>Polyethylene resists acids, greases and oils, and protects the bolt head from corrosion and discolouring. Plug head cover can be used for AS1110 hex bolts and set screws.</p> 	

WATT HAWK





MATERIAL HANDLING



NEW

Lifting Eyes

LIFTING EYE BOLT



ULEB16PD5M

316
STAINLESS STEEL
DIN 580 / A4

LIFTING EYE BOLT



ULEBC5ZD5M

Z/P
DIN 580
GRADE C15E

LIFTING EYE BOLT



ULEBC5GD5M

HDG
DIN 580
GRADE C15E

LIFTING EYE BOLT



ULEBC5YD5M

ZYP
DIN 580
GRADE C15E

Approved,
secure and
certified.

FULL
TRACEABILITY

3-character code

hobson.com.au

KEY

PLN
PLAIN

Z/P
ZINC PLATED
(RoHS COMPLIANT)

ZYP
ZINC YELLOW
PASSIVATE

HDG
HOT DIP
GALVANISED

PWD
POWDER
COAT

PES
POLYESTER

LIFTING EYE NUT



ULEN16PD5M

316
STAINLESS STEEL
DIN 582 / A4

LIFTING EYE NUT



ULENC5ZD5M

Z/P
DIN 582
GRADE C15E

LIFTING EYE NUT



ULENC5GD5M

HDG
DIN 582
GRADE C15E

LIFTING EYE NUT



ULENC5YD5M

ZYP
DIN 582
GRADE C15E

Lifting Eye Bolt & Nut

Markings:

European Conformity (CE)
Working Load Limit (WLL)



NEW

Lifting

FULL
TRACEABILITY

3-character code

hobson.com.au

**LIFTING
POINT D RING
PIVOT**



ULLW08PDP

POWDER COAT
HEC 3776
GRADE 80

**LIFTING
POINT D RING
LONG**



ULLW08PDS

POWDER COAT
HEC 3776
GRADE 80

- Swivel Eye Bolts
- Dee and Bow Shackles
- Weld-On Lifting Points

Weld-On Lifting Point & Swivel Eye Bolts



180° ring rotation

Locking Key



WLL markings
on strap



**LIFTING
SWIVEL EYE
BOLT RING**



ULES08PBRM

POWDER COAT
HEC 3776
GRADE 80

**LIFTING
SWIVEL EYE
BOLT + KEY**



ULES10PBDM

POWDER COAT
HEC 3776
GRADE 100

**LIFTING DEE
SHACKLE
SCREW PIN**



ULSHGSGDD

HDG
HEC 2741
GRADE S

**LIFTING BOW
SHACKLE
SCREW PIN**



ULSHGSGBD

HDG
HEC 2741
GRADE S

**LIFTING BOW
SHACKLE
SAFETY PIN**



ULSHGSGBS

HDG
HEC 2741
GRADE S

Shackles

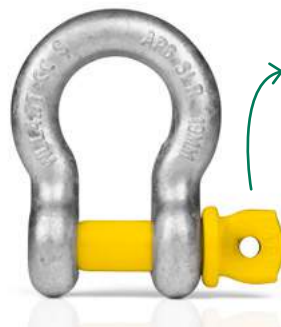

Screw pin

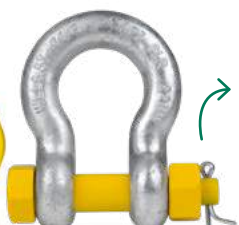

Safety pin



NEW

Hooks & Links

FULL TRACEABILITY

3-character code

hobson.com.au

LATCH HOOK WITH SWIVEL	SLING HOOK WITH CLEVIS	SLING HOOK WITH EYE
ULHK08PAS	ULHK08PLC	ULHK08PLE
POWDER COAT HEC 3776 GRADE 80	POWDER COAT HEC 3776 GRADE 80	POWDER COAT HEC 3776 GRADE 80

Approved, secure and certified.

SAFETY HOOK WITH CLEVIS	SAFETY HOOK WITH EYE	SAFETY HOOK WITH SWIVEL
ULHK08PSC	ULHK08PSE	ULHK08PSS
POWDER COAT HEC 3776 GRADE 80	POWDER COAT HEC 3776 GRADE 80	POWDER COAT HEC 3776 GRADE 80

Sling Safety Grab

Lifting Hooks

GRAB HOOK WITH CLEVIS	GRAB HOOK WITH EYE	CHAIN CONNECTING LINK	CHAIN MASTER LINK ASSEMBLY	CHAIN MASTER LINK
ULHK08PGC	ULHK08PGE	ULCL08PCL	ULCL08PMA	ULCL08PML
POWDER COAT HEC 3776 GRADE 80	POWDER COAT HEC 3776 GRADE 80	POWDER COAT HEC 3776 GRADE 80	POWDER COAT HEC 3776 GRADE 80	POWDER COAT HEC 3776 GRADE 80

Markings:

(CE) European Conformity

(WLL) Working Load Limit

Size Trace code Manufacturer's Mark



NEW

Load Restraint

Complies with
AS/NZS 4380.

**RATCHET TIE ERGO
HOOK / KEEPER
50MM**



URREPEHK050

POLYESTER
L.C. 2500kg
AS 4380

**RATCHET TIE DOWN
HOOK / KEEPER
50MM**



URRTPEHK050

POLYESTER
L.C. 2500kg
AS 4380

**RATCHET TIE DOWN
HOOK / KEEPER
25MM**



URRTPEHK025

POLYESTER
L.C. 750kg
AS 4380

**RATCHET TIE DOWN
HOOK / KEEPER
35MM**



URRTPEHK035

POLYESTER
L.C. 1500kg
AS 4380

Ratchet Tie Down

ERGO

Reverse (pull down) ratcheting system for comfort and greater leverage when tightening.



Standard
Easy to use
and handle.

Heavy duty
hook and keeper.



COOL WAL WIERC



COMMERCIAL



COMMERCIAL



COMMERCIAL							KEY
METRIC HEX BOLT & NUT KBH46GCM HDG AS 1111.1 CLASS 4.6	METRIC HEX BOLT & NUT KBH46ZCM Z/P AS 1111.1 CLASS 4.6	METRIC HEX BOLT & NUT KBH46PCM PLN AS 1111.1 CLASS 4.6	BSW HEX BOLT & NUT KBHMSGW HDG AS 2451 MILD STEEL	BSW HEX BOLT & NUT KBHMSZW Z/P AS 2451 MILD STEEL	METRIC LONG THREAD ASSEMBLED KBX46GCM HDG AS 1111.1 CLASS 4.6	N/P NICKEL PLATED CHR CHROME BRASS BRASS PLN PLAIN Z/P ZINC PLATED (RoHS COMPLIANT) ZYP ZINC YELLOW PASSIVATE ZP BLK ZINC BLACK PASSIVATE HDG HOT DIP GALVANISED MGAL MECHANICAL GALVANISED	
METRIC HEX BOLT BH46ZCM Z/P AS 1111.1 CLASS 4.6	BSW HEX BOLT BHMSZW Z/P AS 2451 MILD STEEL	BSW HEX BOLT BHMSPW PLN AS 2451 MILD STEEL	METRIC HEX SET SCREW BS46GCM HDG AS 1111.2 CLASS 4.6	METRIC HEX SET SCREW BS46ZCM Z/P AS 1111.2 CLASS 4.6	METRIC HEX SET SCREW BS46PCM PLN AS 1111.2 CLASS 4.6		
BSW HEX SET SCREW BSMSZW Z/P AS 2451 MILD STEEL	NEW METRIC HEX SET SCREW BSBRPCM BRASS AS1110.2	METRIC CUP HEAD BOLT & NUT KBC46GCM HDG AS 1390 CLASS 4.6	METRIC CUP HEAD BOLT & NUT KBC46ZCM Z/P AS 1390 CLASS 4.6	METRIC CUP HEAD BOLT & NUT KBC46PCM PLN AS 1390 CLASS 4.6	BSW CUP HEAD BOLT & NUT KBCMSZW Z/P AS 2451 MILD STEEL		HEX WASHER HEAD POLE STEP STEEL KBW58GCM HDG HEC CLASS 5.8
METRIC HEX COACH SCREW BH46GLM HDG AS 1393 CLASS 4.6	METRIC HEX COACH SCREW BH46ZLM Z/P AS 1393 CLASS 4.6	NEW METRIC FLANGED HEX BOLT SERRATED BF46ZCM Z/P HEC 1665 CLASS 4.6	METRIC METAL THREAD PAN PHILLIPS MSMSZPPM Z/P AS 1427:1996 MILD STEEL	METRIC METAL THREAD PAN PHILLIPS MSMSVPPM ZP BLK AS 1427:1996 MILD STEEL	NEW METRIC METAL THREAD PAN POZI MSMSZPZM Z/P AS 1427:1996 MILD STEEL		NEW METRIC THREAD ROLL PAN TORX MTMSZPOM Z/P DIN 7500 MILD STEEL



HEX WASHER HEAD POLE STEP TIMBER



BW58GLM
HDG
HEC
CLASS 5.8

METRIC METAL THREAD PAN COMBI



MSMSZPCM
Z/P
AS 1427:1996
MILD STEEL

METRIC METAL THREAD PAN SLOTTED



MSBRPPS
BRASS
AS 1427:1996

METRIC METAL THREAD CSK PHILLIPS

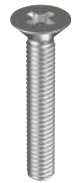

MSMSZCPM
Z/P
AS 1427:1996
MILD STEEL

METRIC METAL THREAD CSK SLOTTED



MSBRPCS
BRASS
AS 1427:1996

Brass

FEATURES OF BRASS

- » Durability
- » Can withstand high temperatures
- » Malleable
- » Corrosion resistance
- » Non-sparking
- » Non-magnetic
- » Fire resistance
- » High electrical conductivity



METRIC HEX NUT



NH05GCM
HDG
AS 1112.3
CLASS 5

METRIC HEX NUT



NH05ZCM
Z/P
AS 1112.3
CLASS 5

METRIC HEX NUT



NH05PCM
PLN
AS 1112.3
CLASS 5

BSW HEX NUT



NHMSGW
HDG
AS 2451

BSW HEX NUT



NHMSZW
Z/P
AS 2451

BSW HEX NUT



NHMSPW
PLN
AS 2451

METRIC LEFT HAND HEX NUT



NH05PDM
PLN
AS 1112.3
CLASS 5

NEW METRIC LEFT HAND HEX NUT



NH05ZDM
Z/P
AS 1112.3
CLASS 5

Left Hand Nut

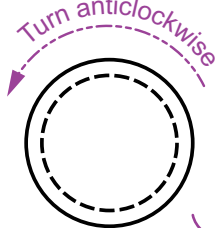

Ideal for applications with rotary parts to counteract rotation.

ACME 6 TPI HEX NUT

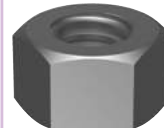

NHMSPA
PLN
HEC
CLASS 5

ACME 6 TPI LEFT HAND HEX NUT



NHMSPB
PLN
HEC
CLASS 5

METRIC HEX NUT



NHBRPCM
BRASS
AS 1112.3

UNC HEX NUT



NHBRPC
BRASS
HEC

BSW HEX NUT



NHBRPW
BRASS
AS 2451

NEW METRIC HEX NUT

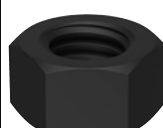

NH05VCM
ZP BLK
AS 1112.3
CLASS 5

Zinc Black Passivate

Acts as a barrier to protect the steel from corrosion. Can be used for electronics and appliances.

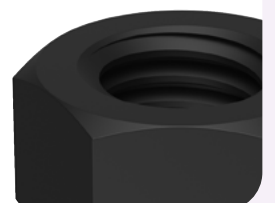



CLASS 4.6

PURLIN BOLTS

**PURLIN
HEX FLANGE
BOLT & NUT**

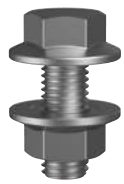

KBFMSGCM

HDG
HEC
CLASS 4.6

**PURLIN
HEX FLANGE
BOLT & NUT**

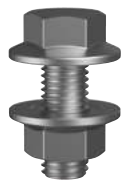

KBFMSZCM

Z/P
HEC
CLASS 4.6

**PURLIN
HEX BOLT NUT
& 2 WASHERS**



KBHMSZCM

Z/P
HEC
CLASS 4.6

**FASCIA
HEX BOLT NUT
& WASHER**



KBAMSGCM

HDG
HEC
CLASS 4.6

**FASCIA
HEX BOLT NUT
& WASHER**



KBAMSZCM

Z/P
HEC
CLASS 4.6

**PURLIN
SHOULDER HEX
BOLT & NUT**



KBOMSZCM

Z/P
HEC
CLASS 4.6



NYLOC®

The special nylon insert prevents loosening caused by vibration.

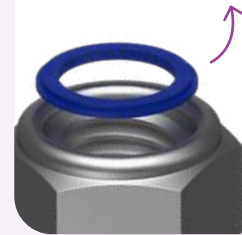

METRIC THIN HEX LOCK NUT

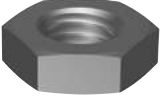

NL05GCM

HDG
AS 1112.4
use with CLASS 5

NEW UNF HEX THIN LOCK NUT



NLG2ZF

Z/P
ANSI B18.2.2
GRADE 2

NEW METRIC HEX THIN LOCK NUT

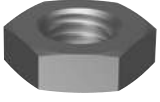

NLBRNCM

N/P
ISO 4035
BRASS

METRIC HEX NUT NYLOC

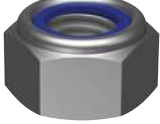

NN06GCM

MGAL
DIN 985
CLASS 6

METRIC HEX NUT NYLOC

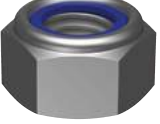

NN06ZCM

Z/P
DIN985
CLASS 6

METRIC FINE HEX NUT NYLOC

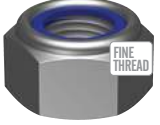

NN06ZFM

Z/P
DIN985
CLASS 6

METRIC HEX NUT NYLOC



NN06YCM

ZYP
DIN 985
CLASS 6

METRIC FINE HEX NUT NYLOC



NN06YFM

ZYP
DIN 985
CLASS 6

BSW HEX NUT NYLOC

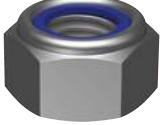

NNG2GW

MGAL
IFI-100NE
GRADE 2

BSW HEX NUT NYLOC

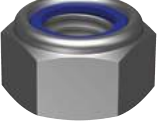

NNG2ZW

Z/P
IFI-100NE
GRADE 2

UNC HEX NUT NYLOC

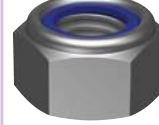

NNG2ZC

Z/P
IFI-100NE
GRADE 2

UNF HEX NUT NYLOC

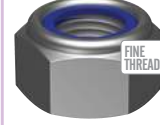

NNG2ZF

Z/P
IFI-100NE
GRADE 2

METRIC HEX THIN NUT NYLOC

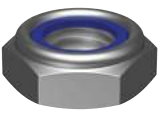

NN05ZTCM

Z/P
ISO 10511
CLASS 04

UNC HEX THIN NUT NYLOC

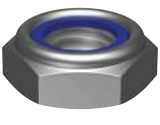

NNG2ZTC

Z/P
ASME B18.16.6
GRADE 2

UNF HEX THIN NUT NYLOC

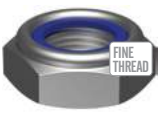

NNG2ZTF

Z/P
ASME B18.16.6
GRADE 2

METRIC SQUARE NUT



NQ05GCM

HDG
DIN 557
CLASS 5

METRIC FINE HEX SLOTTED NUT



NO05ZFM

Z/P
DIN 935
CLASS 5

NEW METRIC HEX SLOTTED NUT



NO05PCM

PLN
DIN 935
CLASS 5

NEW UNF HEX SLOTTED NUT



NOG2ZF

Z/P
ASME B18.2.2
GRADE 2

NEW METRIC HEX K-LOCK NUT



NK05ZECM

Z/P
DIN 934K
CLASS 5

K-Lock Nut

Free spinning tooth-lock washer.

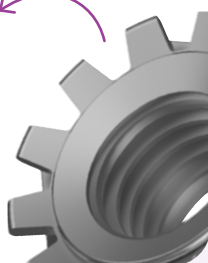

NEW TEE NUT 4 PRONG

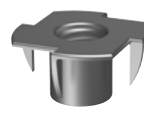

NTMSZCM

Z/P
HEC
MILD STEEL

UNC TEE NUT 4 PRONG

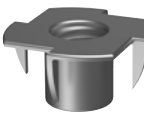

NTMSZC

Z/P
HEC
MILD STEEL

Tee Nut 4 Prong

Prongs to stop the tee nut twisting and moving in the timber.





NEW METRIC WING NUT



NWMSMCM
MGAL
UNI 5448
MILD STEEL

NEW METRIC WING NUT



NWMSZCM
Z/P
UNI 5448
MILD STEEL

Wing Nut

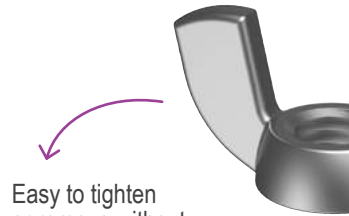

Easy to tighten or remove without the use of a tool.

METRIC DOME HEX NUT



ND05GCM
HDG
DIN 1587
CLASS 5

METRIC DOME HEX NUT



ND05CCM
CHROME
DIN 1587
CLASS 5

METRIC SHEAR NUT



NS05GCM
HDG
HEC
CLASS 5

NEW SEMS SPRING & FLAT PAN PHILLIPS



LSMSMSZPPM
Z/P
JISB 11882017
MILD STEEL

NEW SEMS SPRING & FLAT PAN TORX



LSMSMSZPOM
Z/P
JISB 11882017
MILD STEEL

SEMS

(Abbreviation of asSEMBlies — a screw and washer assembly)

DOUBLE WASHER ASSEMBLY SCREWS

- » Saves time
- » Easy installation

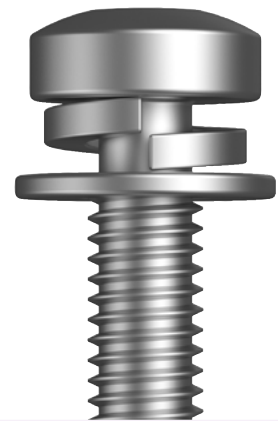

Spanner Selection Chart - Metric



BOLT SIZE	METRIC SPANNER SIZE (MM)				
	METRIC	AS1110 AS1111 ISO 4014	AS1252.1	DIN931 DIN933 DIN934	DIN6921
M4	7	-	7	-	-
M5	8	-	8	8	7
M6	10	-	10	10	8
M7	11	-	11	11	-
M8	13	-	13	13	10
M10	16	-	17	15	13
M12	18	21	19	16	15
M14	21	-	22	18	18
M16	24	27	24	21	21
M18	27	-	27	-	-
M20	30	32	30	27	-
M22	34	36	32	-	-
M24	36	41	36	-	-
M27	41	46	41	-	-
M30	46	50	46	-	-
M33	50	-	50	-	-
M36	55	60	55	-	-

Find more sizes and Imperial Charts on our website hobson.com.au



MILD STEEL

PINS

METRIC
SPLIT PIN



QPSMSZM
Z/P
HEC
MILD STEEL

**R CLIP
HUMPBACK
PIN**



QPRMSZM
Z/P
HEC
MILD STEEL

**NEW SHAFT
LOCKING PIN
D TYPE**



QPHMSYDM
ZYP
HEC
MILD STEEL

LINCH PIN



QPLMSYM
ZYP
HEC
MILD STEEL

**NEW SHAFT
LOCKING PIN
SQUARE**



QPHMSYQM
ZYP
HEC
MILD STEEL

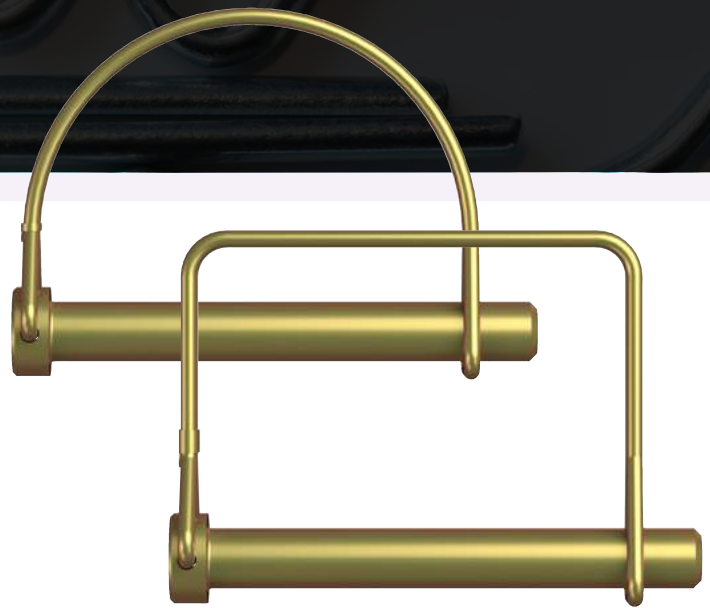

Shaft Locking Pins

Anti-vibration
solution to secure
the end of a shaft,
for round and
square tubes.

LOWE FILLS OILS LET THE



























LOW-TENSILE



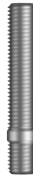
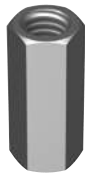
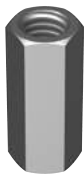
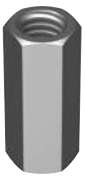



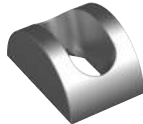





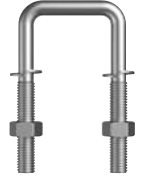
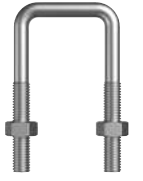







LOW-TENSILE

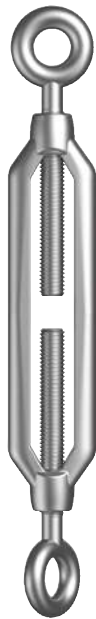
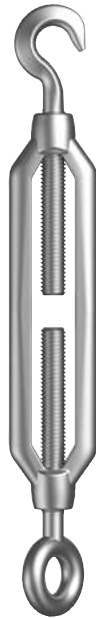
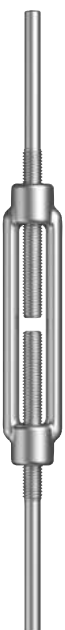

<p>METRIC ALLTHREAD</p>  <p>ASMSZCM</p> <p>Z/P DIN 975 CLASS 4.6 UTS</p>	<p>METRIC ALLTHREAD</p>  <p>ASMSGCM</p> <p>HDG DIN 975 CLASS 4.6 UTS</p>	<p>METRIC FOUNDATION STUD</p>  <p>ASMSGCM</p> <p>HDG DIN 975 CLASS 4.6 UTS</p>	<p>METRIC ALLTHREAD</p>  <p>ASMSPCM</p> <p>PLN DIN 975 CLASS 4.6 UTS</p>	<p>UNC ALLTHREAD</p>  <p>ASMSPC</p> <p>PLN IFI 136C GRADE 1</p>	<p>METRIC LEFT HAND ALLTHREAD</p>  <p>ASMSPDM</p> <p>PLN DIN 975 CLASS 4.6 UTS</p>	<p>METRIC FINE ALLTHREAD</p>  <p>ASMSPFM</p> <p>PLN DIN 975 CLASS 4.6 UTS</p>
	<p>BSW ALLTHREAD</p>  <p>ASMSZW</p> <p>Z/P AS 2451 MILD STEEL</p>	<p>ACME 6 TPI ALLTHREAD</p>  <p>ASMSPA</p> <p>PLN HEC GRADE 1</p>	<p>ACME 6 TPI LEFT HAND ALLTHREAD</p>  <p>ASMSPB</p> <p>PLN HEC GRADE 1</p>	<p>BSW ALLTHREAD</p>  <p>ASMPW</p> <p>PLN AS 2451 MILD STEEL</p>	<p>BSW LEFT HAND ALLTHREAD</p>  <p>ASMSPX</p> <p>PLN AS 2451 MILD STEEL</p>	<p>UNF ALLTHREAD</p>  <p>ASMSPF</p> <p>PLN IFI 136C GRADE 1</p>
<p>BSF ALLTHREAD</p>  <p>ASMSPS</p> <p>PLN AS 2451 MILD STEEL</p>	<p>2BA ALLTHREAD</p>  <p>ASMSPS2BA</p> <p>PLN AS 2451 MILD STEEL</p>	<p>4BA ALLTHREAD</p>  <p>ASMSPS4BA</p> <p>PLN AS 2451 MILD STEEL</p>	<p>METRIC ALLTHREAD</p>  <p>ABBRPCM</p> <p>BRASS HEC DIN 975</p>	<p>BSW ALLTHREAD</p>  <p>ABBRPW</p> <p>BRASS HEC AS 3501</p>	<p>NEW ENGINEER STUD</p>  <p>AES46PCM</p> <p>PLN HEC 938 CLASS 4.6 UTS</p>	<p>METRIC HEX COUPLER</p>  <p>AXHC05GCM</p> <p>HDG HEC CLASS 5</p>
<p>METRIC HEX COUPLER</p>  <p>AXHC05ZCM</p> <p>Z/P HEC CLASS 5</p>	<p>BSW HEX COUPLER</p>  <p>AXHCMSZW</p> <p>Z/P HEC MILD STEEL</p>	<p>NEW ALLTHREAD SOCKET BIT</p>  <p>AXDDPASM</p> <p>S2A STANDARD DRIVE BIT 1/4</p>	<p>Allthread Socket Bit</p>  <p>5 internal rollers for better grip.</p>		<p>ALLTHREAD OUTER REAMER</p>  <p>AXDDPAOM</p> <p>STEEL STANDARD DRIVE BIT 1/4</p>	<p>METRIC WIND BRACE D BRACKET</p>  <p>AXWWCIZ</p> <p>Z/P HEC CAST IRON</p>



ALLTHREAD CUTTER M10/M12		ALLTHREAD CUTTER M10/M12		BSW U BOLT KIT SQ NYLOC + WASHER		METRIC U BOLT KIT SQ + SPRING WASHER		METRIC U BOLT KIT SQUARE		METRIC U BOLT KIT SQUARE			
													
XTBAB-M		XTBD-M		KUSMSGN		KUSMSGSM		KUSMSGCM		KUSMSZCM			
HEC DIES INCLUDED		BLACK HEC REPLACEMENT DIE		HDG HEC MILD STEEL		HDG HEC MILD STEEL		HDG HEC MILD STEEL		Z/P HEC MILD STEEL			
METRIC U BOLT KIT ROUND		BSW U BOLT KIT ROUND		METRIC U BOLT KIT ROUND + WASHER		1/4" BSW U BOLT KIT ROUND		METRIC FOUNDATION L-BOLT		BSW EYE BOLT KIT LARGE		METRIC FORGED EYE BOLT KIT	
													
KURMSGCM		KURMSGW		KURMSGWM		KURMSZW		LB48GCM		KELMSZW		KEFMSGCM	
HDG HEC MILD STEEL		HDG HEC MILD STEEL		HDG HEC MILD STEEL		Z/P HEC MILD STEEL		HDG HEC CLASS 4.8		Z/P HEC MILD STEEL		HDG ISO 898-1 CLASS 4.6	
BSW EYE BOLT KIT		BSW EYE BOLT KIT		METRIC STARTER BAR L BOLT		1/4" BSW HOOK BOLT KIT		TURNBUCKLE EYE & EYE		TURNBUCKLE HOOK & EYE		TURNBUCKLE STUB ENDS	
													
KENMSGW		KENMSZW		LBMSGCM		KHBMSZW		HTBMSGE		HTBMSGH		HTBMSGS	
HDG HEC MILD STEEL		Z/P HEC MILD STEEL		HDG HEC MILD STEEL		Z/P HEC MILD STEEL		HDG HEC MILD STEEL		HDG HEC MILD STEEL		HDG HEC MILD STEEL	
1/4" BSW J BOLT KIT		HEAVY EYE SCREW WOOD		HEAVY HOOK SCREW WOOD		BSW LAG SCREW							
													
KJRMZW0		SEMSZL		SHMSZL		LSMSZW							
Z/P HEC MILD STEEL		Z/P HEC MILD STEEL		Z/P HEC MILD STEEL		Z/P HEC MILD STEEL							









LOW-TENSILE



U SHAPE WITH BAR						U SHAPE WITH BAR						U SHAPE BOLT ON						U STIRRUP ROD STEM						L STIRRUP ROD STEM						L STIRRUP ROD STEM						KEY
																																				BRASS BRASS
GUPGB						GUPSB						GUPGT						GUSGR						GLSGR						GLSGR035						
HDG MILD STEEL HEC						316 STAINLESS STEEL HEC						316 STAINLESS STEEL HEC						HDG HEC MILD STEEL						HDG HEC MILD STEEL						HDG HEC MILD STEEL						PLN PLAIN
ANGLE BRACKET M12 / 2 HOLES						ANGLE BRACKET M12 / 3 HOLES						T STIRRUP ROD STEM						T BLADE BOLT ON						T BLADE BOLT ON EXTRA H/DUTY						ANGLE BRACKET M10 / 2 HOLES						
GABGS12						GABGS12						GTSGR						GTPGB						GTXGB						GABGS10						ZYP ZINC YELLOW PASSIVATE
HDG HEC MILD STEEL						HDG HEC MILD STEEL						HDG HEC MILD STEEL						HDG HEC MILD STEEL						HDG HEC MILD STEEL						HDG HEC MILD STEEL						
ANGLE BRACKET M12 / 4 HOLES						ANGLE BRACKET M16 / 2 HOLES						ANGLE BRACKET M12 / 4 HOLES						ANGLE BRACKET M16 / 2 HOLES						ANGLE CONNECTOR TIMBER M6						ANGLE CONNECTOR TIMBER M12/16						HDG HOT DIP GALVANISED
GABGS12						GABGS12						GABGS12						GABGS12						GACGT06						GACGT12016						MGAL MECHANICAL GALVANISED
HDG HEC MILD STEEL						HDG HEC MILD STEEL						HDG HEC MILD STEEL						HDG HEC MILD STEEL						HDG HEC MILD STEEL						HDG HEC MILD STEEL						
ANGLE CONNECTOR TIMBER M12						HEAVY DUTY ANGLE BRACKET RIB						D ANCHOR BRACKET M6 / 4 HOLES						CONNECTOR Z BRACKET						NEW SHACKLE D STANDARD						Z275 GALVANISED Z275						
GACGT12						MTFOKS210						GDAGP4M						GTCGZ						HSHMSGD						S2A S2 ALLOY STEEL						
HDG HEC MILD STEEL						304 STAINLESS STEEL HEC						HDG HEC MILD STEEL						HDG HEC MILD STEEL						HDG HEC MILD STEEL												
STEEL						STEEL						STEEL						STEEL						STEEL						STEEL STEEL						
STEEL						STEEL						STEEL						STEEL						STEEL												



COATINGS COMPARISON

Icon/Coating	Standard	Coating Thickness	Corrosion Resistance	Description
 HDG HOT DIP GALVANISED	AS/NZS 1214	50µm	HIGH	HDG products are used where a high level of corrosion resistance is required. HDG products are recommended for long-term outdoor applications.
 MGAL MECHANICALLY GALVANISED	ISO 12683	50µm	HIGH	MGAL provides better abrasion resistance than HDG and does not introduce any risk of hydrogen embrittlement. MGAL products provide similar corrosion resistance to HDG.
 ZFS ZINC FLAKE SILVER	ISO 10683	10µm	HIGH	ZFS provides high corrosion resistance without introducing any risk of hydrogen embrittlement. Thin coating thickness allows external thread to be mated with standard internal thread (no over-tapping).
 Z275 HOT DIP GALVANISED (NON-THREADED)	AS/NZS 1397	40µm	HIGH	Z275 is the coating class for non-threaded HDG products. Z275 is the nominal requirement for steel straps, and tie downs used for framing structures.
 Z/P ZINC PLATED (ROHS COMPLIANT)	ISO 4042	5µm	LOW	Product is electroplated with zinc which is then passivated with a transparent conversion layer. Z/P products are recommended for indoor and noncorrosive environments.
 ZYP ZINC YELLOW PASSIVATE	ISO 4042	5µm	LOW	Product is electroplated with zinc which is then passivated with an iridescent yellow conversion layer. ZYP products are recommended for indoor and non-corrosive environments.
 PLN PLAIN (NO COATING)	-	-	-	No additional coating applied. Products are supplied lightly oiled to inhibit rust in the packaging and assist with installation.



G300 ROLL FORMED STRUCTURAL STEEL

Timber Connectors

Multi-purpose metal connectors for timber construction.

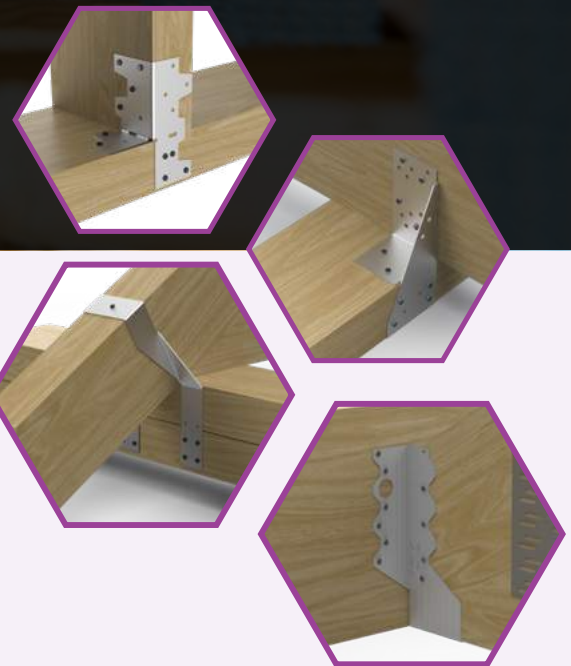

NEW MULTI-GRIP TIMBER



HGMMGD

Z275
HEC
G300

NEW JOIST HANGER TIMBER



HHJMGD

Z275
HEC
G300

NEW STRAP TIE DOWN 400

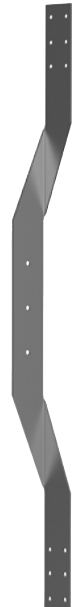

GSCMG12P400

Z275
HEC
G300

NEW STRAP TIE DOWN 600



GSCMG12P600

Z275
HEC
G300

NEW TRIPLE GRIP TIMBER



HGTMGR

Z275
HEC
G300

NEW TRIPLE GRIP TIMBER



HGTMGL

Z275
HEC
G300

FLAT CONNECTOR TIMBER M12



GFCGF30050

HDG
HEC
MILD STEEL

FLAT CONNECTOR TIMBER M12



GFCGF45050

HDG
HEC
MILD STEEL

FLAT CONNECTOR TIMBER M12



GFCGF45065

HDG
HEC
MILD STEEL

FLAT CONNECTOR TIMBER M16



GFCGF16450

HDG
HEC
MILD STEEL

CONNECTOR BOND BEAM



GTBGB

HDG
HEC
MILD STEEL

CONNECTOR NAIL PLAIN SHANK



QNOPM

HEC
CARBON STEEL



G300 ROLL FORMED STRUCTURAL STEEL

Bracing Straps

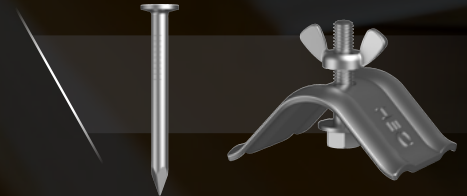

Use with nail and tensioner.

Designed to brace timber framed walls in domestic buildings.

Applicable to single and two-storey construction.

BRACING 0.8 STRAP PUNCHED

316

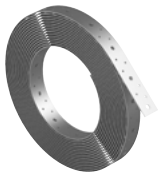

GSB1608P30

316
STAINLESS STEEL
AS 1684

BRACING 0.8 STRAP PUNCHED

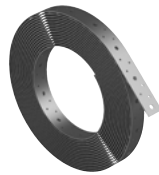

GSBMG08P30

Z275
AS 1684
G300

BRACING 0.8 STRAP UNPUNCHED

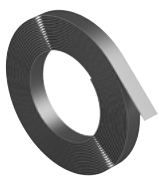

GSBMG08U30

Z275
AS 1684
G300

BRACING 1.0 STRAP PUNCHED

316

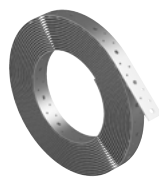

GSB1610P30

316
STAINLESS STEEL
AS 1684

BRACING 1.0 STRAP PUNCHED

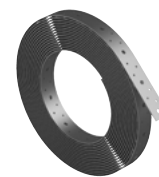

GSBMG10P30

Z275
AS 1684
G300

NEW WING NUT TENSIONER



TXDDPWN
S2 ALLOY STEEL
STANDARD
DRIVE BIT 1/4

NEW HEX BRACING STRAP TENSIONER



GSTMGF30

Z275
HEC
G350

Tensioner

Use with bracing straps

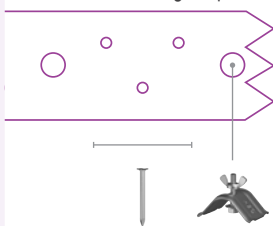

With wing nut



With 3/8" hex flange head screw.

BRACING 1.2 STRAP PUNCHED

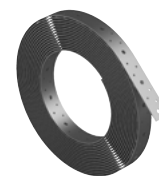

GSBMG12P30

Z275
AS 1684
G300

Check it out in:
DRILLX

WUJGO



MUNGO[®]



MUNGO



Chemical

Injection system and capsule



Swiss Engineering



Volatile Organic Compounds FREE



Leadership in Energy and Environmental Design TEST REPORT



MIT-700RE PURE EPOXY 

Slow Curing  For cracked and non-cracked concrete

 For diamond drilled holes

MUCMT7001710161

585 ML CARTRIDGE

MIT-HYBRID PLUS VINYLESTER URETHANE

Fast Curing  For cracked and non-cracked concrete



MUCMTHYP1710097

MORTAR STYRENE FREE 400 ML CARTRIDGE

MIT-SE PLUS VINYLESTER

Fast Curing  For cracked and non-cracked concrete



MUCMTSEP1710017

MORTAR STYRENE FREE 300 ML

MVA RESIN CAPSULE



MUCMVA

EPOXY-ACRYLATE M8, M10, M12, M14, M16, M20, M24, M30

MIT-SE PLUS VINYLESTER

Fast Curing  For cracked and non-cracked concrete



MUCMTSEP1710026

MORTAR STYRENE FREE 400 ML

MIT-SP POLYESTER

Fast Curing  For non-cracked concrete



MUCMTSP01710050

MORTAR STYRENE FREE 300 ML

MIT-SP POLYESTER

Fast Curing  For non-cracked concrete



MUCMTSP01710052

MORTAR STYRENE FREE 400 ML



MIT Compatibility of Mungo Injection Technology

MIT700RE	MIT-Hybrid Plus	MIT-SE Plus	MIT-SP
<p>Pure Epoxy</p>	<p>Vinylester urethane mortar, styrene free</p>	<p>Vinylester mortar, styrene free</p>	<p>Polyester mortar, styrene free</p>
<p>Option 1 REBAR CE</p>	<p>Option 1 REBAR CE</p>	<p>Option 1 REBAR ETAG 029 CE</p>	<p>ETAG 029 Option 7 CE</p>
	<p>Concrete</p>	<p>Brick</p>	<p>Lightweight Concrete</p>

recommended

suitable



MUNGO







Chemical



Swiss Engineering

Sleeves and accessories

<p>MIT-IGH ANCHOR SLEEVE</p>  <p>MUCMTIGH</p> <p>Z/P INT THREAD EXT KNURL</p>	<p>MIT-SH-K1 SLEEVE</p>  <p>MUCMTSH1</p> <p>NYLON FOR HOLLOW BASE MATERIAL</p>	<p>MIT-SH-K2 SLEEVE</p>  <p>MUCMTSH2</p> <p>NYLON FOR MIT-SE PLUS/ MIT-SP</p>	<p>MIT-SH-K0 SLEEVE</p>  <p>MUCMTSH0</p> <p>NYLON FOR HOLLOW BASE MATERIAL</p>	<p>MIT-SH-S0 SLEEVE</p>  <p>MUCMTSHS</p> <p>METAL 1M</p>		
<p>MIT-MI-2 MIXER</p>  <p>MUCMTMI2</p> <p>MIT-HYBRID PLUS / MIT-SE PLUS / MIT-SP</p>	<p>MIT-MI-4 MIXER</p>  <p>MUCMTMI4</p> <p>FOR MIT-HYBRID PLUS, MIT700RE</p>	<p>MIT-MI-V1 MIXER EXTENSION</p>  <p>MUCMTMV1</p> <p>PLASTIC 500MM</p>	<p>MIT-MI-V2 MIXER EXTENSION</p>  <p>MUCMTMV2</p> <p>PVC 1M</p>	<p>MIT-BS-MA BRUSH ADAPTER</p>  <p>MUCMTBMA</p> <p>STEEL SDS-PLUS M6</p>	<p>MIT-AP-HG1 PURGING PUMP</p>  <p>MUCMTAPG</p> <p>TOOL 840 ml</p>	<p>MIT-BS-MV BRUSH EXTENSION</p>  <p>MUCMTBMV</p> <p>TOOL ACCESSORY</p>
<p>MIT-BN-H1 NYLON HAND BRUSH</p>  <p>MUCMTBNH</p> <p>TOOL</p>	<p>MIT-BS-H0 STEEL HAND BRUSH</p>  <p>MUCMTBH0</p> <p>TOOL</p>	<p>MIT-BS-H1 STEEL HAND BRUSH</p>  <p>MUCMTBH1</p> <p>TOOL</p>	<p>MIT-BS-M1 STEEL BRUSH-POWER</p>  <p>MUCMTBM1</p> <p>TOOL ACCESSORY</p>		<p>MIT-VS PISTON PLUGS</p>  <p>MUCMTVS</p> <p>TOOL ACCESSORY</p>	



**MPU-P50
PU FOAM
GEN PURPOSE**



MUCMPU50

DISPENSER FOAM
UP TO 50L YIELD
750 ML

**MPU-M50
PU FOAM
HAND HELD**



MUCMPUM5

DISPENSER FOAM
UP TO 50L YIELD
750 ML

**MRM-PU
FOAM
CLEANER**



MUCMRMPU

FOR PU FOAM
AND DISPENSER
500 ML

**MPP-M
DISPENSER GUN**



MUCMPPM0

NY UV
FOR MPU-P50 FOAM
NYLON / ZINC STEEL

MPP-K DISPENSER



MUCMPPK0

NY UV
FOR MPU-P50 FOAM
NYLON / ZINC STEEL

MPP-H DISPENSER



MUCMPPH0

NY UV
FOR MPU-P50 FOAM
NYLON / ZINC STEEL

**MIT-PP-H2
MANUAL INJECTION**



MUCMTPH21710009

INJECTION GUN
FOR MIT 400 ML

**MIT-PP-H2
MANUAL INJECTION**



MUCMTPH21710019

INJECTION GUN
FOR MIT 300/585 ML

**MIT-PP-H2
MANUAL INJECTION**



MUCMTPH21710029

INJECTION GUN
FOR MIT 300 ML

**MIT-PP-A
INJECTION METAL GUN**



MUCMTPPA1710021

CORDLESS
FOR MIT 400 ML

**MIT-PP-A
INJECTION METAL GUN**



MUCMTPPA1710046

CORDLESS
FOR MIT 300 ML

**MIT-PP-HK STEEL
SYSTEM-CASE**



MUCMTPHK1710201

EASY-PRESS
FOR MIT 300 ML

**MIT-PP-HK STEEL
SYSTEM-CASE**



MUCMTPHK1710203

EASY-PRESS
FOR MIT 400 ML

**MIT-AP-D1
COMPRESSED AIR TOOL**



MUCMTAPD

METAL
1/4" INTERNAL THREAD

ICON	MEANING
	NON-CRACKED CONCRETE
	CRACKED CONCRETE
	BRICK
	PERFORATED BRICK
	LIGHTWEIGHT CONCRETE
	SAND-LIME BRICK
	GYPSUM
	PLASTERBOARD /CHIPBOARD
	METAL
	NATURAL STONE
	POLYSTYRENE



MUNGO



Mechanical Anchors















Swiss Engineering

European Technical Assessment (ETA) approved

<p>THROUGHBOLT WITH WASHER</p>  <p>MUMM1T0 Z/P CARBON STEEL M1T</p>	<p>THROUGHBOLT WITH WASHER</p>  <p>MUMM1TR 316 STAINLESS STEEL M1TR</p>	<p>THROUGHBOLT WITH WASHER</p>  <p>MUMM20 Z/P CARBON STEEL M2</p>	<p>THROUGHBOLT WITH WASHER</p>  <p>MUMM2F HDG CARBON STEEL M2F</p>	<p>European Technical Assessment (ETA) approved</p>		
<p>THROUGHBOLT WITH WASHER</p>  <p>MUMM2R 316 STAINLESS STEEL M2R</p>	<p>INTERNALLY THREADED BOLT</p>  <p>MUMM2I Z/P CARBON STEEL M2-I</p>	<p>INTERNALLY THREADED BOLT</p>  <p>MUMM2RI 316 STAINLESS STEEL M2R-I</p>	<p>BOLT & NUT HEAVY DUTY ANCHOR</p>  <p>MUMHL4SZ 316 STAINLESS STEEL HL-B (SZ-B)</p>			
<p>HEX HEAD CONCRETE SCREW HEX</p>  <p>MUMMCSS ZFS CARBON STEEL MCS-S</p>	<p>CSK HEAD CONCRETE SCREW TORX</p>  <p>MUMMCSSK Z/P CARBON STEEL MCS-SK</p>	<p>PAN HEAD CONCRETE SCREW TORX</p>  <p>MUMMCSP Z/P CARBON STEEL MCS-P</p>	<p>VERTICAL HANGER CONCRETE SCREW HEX</p>  <p>MUMMCSI Z/P CARBON STEEL MCS-I</p>	<p>HEX HEAD CONCRETE SCREW HEX</p>  <p>MUMMCSRS 316 STAINLESS STEEL MCSR-S</p>	<p>CSK HEAD CONCRETE SCREW TORX</p>  <p>MUMMCSRK 316 STAINLESS STEEL MCSR-SK</p>	<p>PAN HEAD CONCRETE SCREW TORX</p>  <p>MUMMCSR-P 316 STAINLESS STEEL MCSR-P</p>



<p>DROP-IN ANCHOR</p>  <p>MUMMEAE</p> <p>Z/P CARBON STEEL MEA</p>	<p>DROP-IN ANCHOR</p> <p>316</p>  <p>MUMMEARE</p> <p>316 STAINLESS STEEL MEAR</p>	<p>HOLLOW CEILING ANCHOR</p>  <p>MUMMHDA</p> <p>Z/P CARBON STEEL MHDA</p>	<p>SETTING TOOL FOR MEA WITH HAND GUARD</p>  <p>MUMMEAWZ</p> <p>Z/P MEA-WZ</p>	<p>SETTING TOOL FOR MEAR WITH HAND GUARD</p>  <p>MUMMEARW</p> <p>Z/P MEAR-WZ</p>		
<p>SETTING TOOL FOR MEA</p>  <p>MUMMEASD</p> <p>ALLOY STEEL SDS-PLUS</p>	<p>CONCRETE FRAME ANCHOR POZI DRIVE</p>  <p>MUMMMS</p> <p>Z/P CARBON STEEL MMS</p>	<p>TRIM HEAD 8.3 WALL SCREW TORX DRIVE</p>  <p>MUMMRSH</p> <p>Z/P CARBON STEEL MRS-H</p>	<p>CSK HEAD 11.5 WALL SCREW TORX DRIVE</p>  <p>MUMMRSU</p> <p>Z/P CARBON STEEL MRS-U</p>	<p>CEILING ANCHOR</p>  <p>MUMMAN</p> <p>Z/P CARBON STEEL MAN</p>	<p>EXPRESS NAIL</p>  <p>MUMMEN</p> <p>Z/P CARBON STEEL MEN</p>	<p>METAL DISC DIAM 38MM</p>  <p>MUMMDBM3</p> <p>Z/P MDB-M</p> <p>METAL DISC DIAM 38MM WHITE</p>  <p>MUMMDBMW</p> <p>Z/P MDB-M</p>



- ETA -

European Technical Assessment
Directly compatible with AS 5216

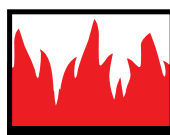

- Fire Rated -

Assessment of Resistance
Under Fire Exposure

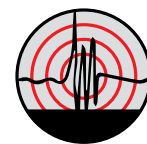

- Category C1 and/or C2 -

Seismic Load Approval Performance



MUNGO



Lightweight Anchors



Swiss Engineering

**MN
NYLON PLUG**



MUNMNPP0

NY PA6
SOLID BUILDING MATERIALS

**MQ QUATTRO®
NYLON COLLAR PLUG**



MUNMQPP0

NY PA6
ALL BUILDING MATERIALS

**MU
NYLON MULTI PLUG**

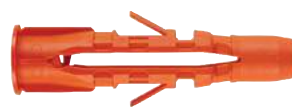

MUNMUPP0

NY PA6
CAVITY FIXINGS

MOB NYLON PLUG



MUNMOB00

NY PA6
ORANGE BOX
MU MQ

**MNK NYLON
COLLAR PLUG**



MUNMNK00

NY PA6

**MNL NYLON
LONG PLUG**



MUNMNL00

NY PA6
SOLID MATERIALS

**ML HOLLOW
BRICK PLUG**



MUNML060

NY PA6
DIAM 6/8

**ML HOLLOW
BRICK PLUG**



MUNML100

NY PA6
DIAM 10/14

**MLK HOLLOW
BRICK
COLLAR PLUG**



MUNMLK08

NY PA6
DIAM 8

**MGV
SCAFFOLD
SCREW EYE**



MUNMGV00

Z/P
CARBON STEEL

**MGVM
SCAFFOLD EYE
BOLT**



MUNMGVM0

Z/P
CARBON STEEL

**MGD
SCAFFOLD
PLUG**



MUNMGD00

NY PA6

**MQL-ST
NYLON FRAME
PLUG**



MUNMQLST

UNIVERSAL
ZINC STEEL

**MQL - STR
NYLON FRAME
PLUG**



MUNMQLSR

UNIVERSAL
316 STAINLESS
STEEL

**MQL-SS
NYLON FRAME
PLUG**



MUNMQLSS

UNIVERSAL
ZINC STEEL















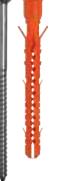













**MQLK-STB
NYLON FRAME
COLLAR PLUG**



MUNMQLKB

UNIVERSAL
ZINC STEEL





















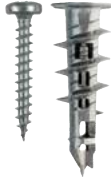

<p>MLK-STBF NYLON FRAME COLLAR PLUG</p>  <p>MUNMQLKF</p> <p>UNIVERSAL HDG STEEL</p>	<p>MLK-STBR NYLON FRAME COLLAR PLUG</p> <p>316</p>  <p>MUNMQLKR</p> <p>UNIVERSAL 316 STAINLESS STEEL</p>	<p>MB-S NYLON FRAME PLUG</p>  <p>MUNMBS00</p> <p>SOFT MATERIALS ZINC STEEL</p>	<p>MB-ST NYLON FRAME PLUG</p>  <p>MUNMBST0</p> <p>SOFT MATERIALS ZINC STEEL</p>	<p>MB-STR NYLON FRAME PLUG</p> <p>316</p>  <p>MUNMBSTR</p> <p>SOFT MATERIALS 316 STAINLESS STEEL</p>	<p>MB-SS NYLON FRAME PLUG</p>  <p>MUNMBSS0</p> <p>SOFT MATERIALS ZINC STEEL</p>	<p>MB-SSF NYLON FRAME PLUG</p>  <p>MUNMBSSF</p> <p>SOFT MATERIALS HDG STEEL</p>
<p>MB-SSR NYLON FRAME PLUG</p> <p>316</p>  <p>MUNMBSSR</p> <p>SOFT MATERIALS 316 STAINLESS STEEL</p>	<p>MBK-STB NYLON FRAME PLUG</p>  <p>MUNMBKSB</p> <p>SOFT MATERIALS ZINC STEEL</p>	<p>MBK-STBR NYLON FRAME PLUG</p> <p>316</p>  <p>MUNMBKSR</p> <p>SOFT MATERIALS 316 STAINLESS STEEL</p>	<p>MB-SK NYLON FRAME PLUG & MN5</p>  <p>MUNMBSK0</p> <p>SOFT MATERIALS ZINC STEEL</p>	<p>MB-SKM NYLON FRAME PLUG & M5</p>  <p>MUNMBSKM</p> <p>SOFT MATERIALS ZINC STEEL</p>	<p>MBR-S NYLON FRAME PLUG</p>  <p>MUNMBRS0</p> <p>SOLID MATERIALS ZINC STEEL</p>	<p>MBR-ST NYLON FRAME PLUG</p>  <p>MUNMBRST</p> <p>SOLID MATERIALS ZINC STEEL</p>
<p>MBR-STR NYLON FRAME PLUG</p> <p>316</p>  <p>MUNMBRTR</p> <p>SOLID MATERIALS 316 STAINLESS STEEL</p>	<p>MBR-SS NYLON FRAME PLUG</p>  <p>MUNMBRSS</p> <p>SOLID MATERIALS ZINC STEEL</p>	<p>MBR-SSR NYLON FRAME PLUG</p> <p>316</p>  <p>MUNMBRSR</p> <p>SOLID MATERIALS 316 STAINLESS STEEL</p>	<p>MBR-SK NYLON FRAME PLUG & MN5</p>  <p>MUNMBRSK</p> <p>SOLID MATERIALS ZINC STEEL</p>	<p>MBR-SKM NYLON FRAME PLUG & M5</p>  <p>MUNMBRSM</p> <p>SOLID MATERIALS ZINC STEEL</p>	<p>MBRK-STB NYLON FRAME PLUG</p>  <p>MUNMBRKS</p> <p>SOLID MATERIALS ZINC STEEL</p>	<p>MBR-XT NYLON FRAME PLUG</p>  <p>MUNMBRXT</p> <p>HIGH PERFORMANCE ZINC STEEL</p>
<p>MBR-XTR NYLON FRAME PLUG</p> <p>316</p>  <p>MUNMBR XR</p> <p>HIGH PERFORMANCE-316 STAINLESS STEEL</p>	<p>MBRK-XTBR NYLON FRAME PLUG</p> <p>316</p>  <p>MUNMBRKR</p> <p>HIGH PERFORMANCE-316 STAINLESS STEEL</p>	<p>MNAR-S HAMMER SCREW CSK COLLAR</p> <p>304</p>  <p>MUNMNARS</p> <p>NYLON & 304 STAINLESS STEEL</p>	<p>MNAR-Z HAMMER SCREW CYLIN COLLAR</p> <p>304</p>  <p>MUNMNARZ</p> <p>NYLON & 304 STAINLESS STEEL</p>	<p>MNAF HAMMER SCREW</p>  <p>MUNMNAFB</p> <p>DARK BROWN NYLON & ZINC STEEL</p>	<p>MNAF HAMMER SCREW</p>  <p>MUNMNAFW</p> <p>WHITE NYLON & ZINC STEEL</p>	<p>MNAF HAMMER SCREW</p>  <p>MUNMNAFY</p> <p>YELLOW NYLON & ZINC STEEL</p>



MUNGO









MNA-G HAMMER SCREW		MNA-G HAMMER SCREW		MNA-S HAMMER SCREW		MNA-S HAMMER SCREW		MNA-Z HAMMER SCREW		MST SNAPTOGGLE WALL ANCHOR		KEY	
													Z/P ZINC PLATED (RoHS COMPLIANT)
MUNMNAGO		MUNMNAGZ		MUNMNAS0		MUNMNASN		MUNMNAZ0		MUSMST00			ZYP ZINC YELLOW PASSIVATE
Z/P LARGE COLLAR NYLON / ZINC STEEL		Z/P LARGE COLLAR NYLON / ZINC STEEL		Z/P CSK COLLAR NYLON / ZINC STEEL		Z/P CSK COLLAR NYLON / ZINC STEEL		Z/P CYLINDRICAL COLLAR NYLON / ZINC STEEL		ZYP NYLON / ZINC STEEL			ZFS ZINC FLAKE SILVER
MDB NYLON DISC		MJP25 JET PLUG METAL		MJP32 JET PLUG METAL		MJP39 JET PLUG METAL		MJP39-S JET PLUG METAL		HDG HOT DIP GALVANISED			HARD HARDENED STEEL
										SY AB SYNTHETIC ABRASIVE			NYLN NYLON NATURAL
MUNMDB00		MUSMJ250		MUSMJ320		MUSMJ390		MUSMJ39S		NY UV NYLON BLACK UV STABLE		NY PA6 NYLON POLYAMIDE PA6	
NYLN MDB NYLON DISC WHITE		Z/P 25MM STEEL		Z/P 32MM STEEL		Z/P 39MM STEEL		Z/P 39MM PAN HEAD		PLA PLASTIC		ALLOY ALLOY STEEL	
MJP32-S JET PLUG METAL		MJPM JET PLUG METAL		MEF EASY-FIX		MFJ25 FIBER JET POLYAMIDE		MFJ32-S FIBER JET POLYAMIDE		MFJ32 FIBER JET POLYAMIDE		S2A S2 ALLOY STEEL	
												DBL DIAMOND BLADE	
MUSMJ32S		MUSMJPM0		MUSMEF00		MUSMFJ25		MUSMFJ3S		MUSMFJ32		STEEL STEEL	
Z/P 32MM PAN HEAD		Z/P METRIC THREAD STEEL		Z/P STEEL		NY PA6 25MM		NY PA6 32MM PAN HEAD		NY PA6 32MM			
MSN STEEL NAIL		MK-M CAVITY TOGGLE		DUO-BIT FOR MJP/MFJ		SQ-BIT FOR MJPM							
													
MUSMSN00		MUSMKM00		MUSBITDU		MUSBITSQ							
Z/P 12 X 30 STEEL		Z/P WITH THREADED ROD STEEL		S2A		S2A							



Insulation Fixings & Case



Swiss Engineering

MDD-CE INSULATION FIXING	MDI INSULATION PLUG	MIDS-K INSULATION NAIL	MIS INSULATION FIXING	MDD-S INSULATION FIXING	MIP INSULATION FIXING	MDS INSULATION FIXING
						
MUIMDDCE	MUIMDI25	MUIMIDSK	MUIMIS00	MUIMDDS0	MUIMIP00	MUIMDS00
PLA DIAM 60MM	NY PA6	Z/P DIAM 54MM STEEL	NYLN LIGHT WEIGHT DIAM 88MM	NYLN 60MM NYLON / ZINC STEEL	NYLN FOR MINERAL WOOL DIAM 45MM	NY UV FIXING DIAM 90MM

MIDS INSULATION NAIL	MIDSR INSULATION NAIL
	
MUIMIDS	MUIMIDSR
Z/P STEEL DIAM 30/35MM	304 STAINLESS STEEL DIAM 30/35MM

MKS-P SAMPLE CASE



MUXMSKP

LARGE SELECTION
MUNGO PRODUCTS
-SAMPLES-

Includes a large selection of Mungo® products in a handy carry case.



MUNGO® Sample Case





MUNGO

























Drill Bits & Abrasives



Swiss Engineering

<p>MHP-T DRILL BIT</p>  <p>MUDMHPT0</p> <p>SDS-PLUS 3-CUTTER</p>	<p>MHP-Y DRILL BIT</p>  <p>MUDMHPY0</p> <p>SDS-PLUS Y-CUTTER</p>	<p>MHP-D DRILL BIT</p>  <p>MUDMHDP0</p> <p>SDS-PLUS 2-CUTTER</p>	<p>JET-TRAC TRIPLO DRILL BIT</p>  <p>MUDJTTPR</p> <p>SDS-PLUS 3-CUTTER</p>	<p>SDS-MAX DRILL BIT</p>  <p>MUDSDSMX</p> <p>SDS-MAX 6-CUTTER</p>	<p>MHX-T DRILL BIT</p>  <p>MUDMHXT0</p> <p>SDS-MAX 3-CUTTER</p>	<p>MHX-Y DRILL BIT</p>  <p>MUDMHXY0</p> <p>SDS-MAX Y-CUTTER</p>
<p>MFB DIAMOND DRILL BIT</p>  <p>MUDMFB00</p> <p>DBL 10MM CHUCK SIZE</p>	<p>MMP SPADE CHISEL</p>  <p>MUDMMPSC</p> <p>HARD SDS-PLUS</p>	<p>MMP TILE CHISEL</p>  <p>MUDMMPTC</p> <p>HARD SDS-PLUS</p>	<p>MMP FLAT CHISEL</p>  <p>MUDMMPFC</p> <p>HARD SDS-PLUS</p>	<p>MMP HOLLOW CHISEL</p>  <p>MUDMMPHC</p> <p>HARD SDS-PLUS</p>	<p>MMP POINTED CHISEL</p>  <p>MUDMMPPC</p> <p>HARD SDS-PLUS</p>	<p>MMX POINTED CHISEL</p>  <p>MUDMMXPC</p> <p>HARD SDS-MAX</p>



<p>MMX SPADE CHISEL</p>  <p>MUDMMXSC</p> <p>HARD SDS-MAX</p>	<p>MMX BUSHING TOOL</p>  <p>MUDMMXBT</p> <p>HARD SDS-MAX</p>	<p>MMX CHANNEL CHISEL</p>  <p>MUDMMXCC</p> <p>HARD SDS-MAX</p>	<p>MMX FLAT CHISEL</p>  <p>MUDMMXFC</p> <p>HARD SDS-MAX</p>	<p>MMX SEAM TOOL</p>  <p>MUDMMXST</p> <p>HARD SDS-MAX</p>	<p>MMX WING CHISEL</p>  <p>MUDMMXWC</p> <p>HARD SDS-MAX</p>	<p>KEY</p>  <p>SDS-PLUS</p>  <p>SDS-MAX</p>	
<p>MMX SLOTTING CHISEL</p>  <p>MUDMMXLC</p> <p>HARD SDS-MAX</p>	<p>MHX HOLLOW ADAPTOR</p>  <p>MUDMHXCA</p> <p>PLA SDS-MAX</p>	<p>MHX HOLLOW DRILL BIT WITH ADAPTOR</p>  <p>MUDMHXC0</p> <p>SDS-MAX</p>	<p>MHP HOLLOW ADAPTOR</p>  <p>MUDMHPCA</p> <p>PLA SDS-PLUS</p>	<p>MHP HOLLOW DRILL BIT WITH ADAPTOR</p>  <p>MUDMHPC0</p> <p>SDS-PLUS</p>			
<p>MPC PRO CUT CUTTING DISC</p>  <p>MUDMPCP1</p> <p>SY AB 1.0-1.9</p>	<p>MPC PRO CUT CUTTING DISC</p>  <p>MUDMPCP2</p> <p>SY AB 2.5 - 3.0</p>	<p>MPG PRO GRIND GRINDING DISC</p>  <p>MUDMPGPG</p> <p>SY AB 6.5</p>	<p>DS500 DIAMOND BLADE</p>  <p>MUDDS500</p> <p>DBL DIAMOND BLADE</p>	<p>MDG GC-HARD GRINDING DISC</p>  <p>MUDMDGGC</p> <p>DBL DIAMOND BLADE</p>			
<p>MDC LASER BETON</p>  <p>MUDMDCLB</p> <p>DBL DIAMOND BLADE</p>	<p>MDC POWER M DIAMOND BLADE</p>  <p>MUDMDCPM</p> <p>DBL DIAMOND BLADE</p>	<p>MDC COBRA DIAMOND BLADE</p>  <p>MUDMDCC0</p> <p>DBL DIAMOND BLADE</p>	<p>MDC VIPER DIAMOND BLADE</p>  <p>MUDMDCV0</p> <p>DBL DIAMOND BLADE</p>				

COOLCAT FRUIT











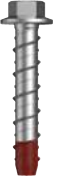

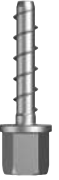
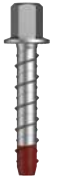
CONSTRUCT®

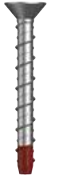

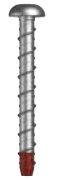
XBolt

Wide range of concrete Screw Anchors

<p>SCREW ANCHOR HEX FLANGE</p> <p>XBolt</p>  <p>MXHMSGM</p> <p>MGAL CARBON STEEL HEC</p>	<p>SCREW ANCHOR HEX FLANGE</p> <p>XBolt</p>  <p>MXHMSYM</p> <p>ZYP CARBON STEEL HEC</p>	<p>SCREW ANCHOR VERTICAL HANGER</p> <p>XBolt</p>  <p>MXVMSZIM</p> <p>Z/P CARBON STEEL HEC</p>	
<p>SCREW ANCHOR COUPLER</p> <p>XBolt</p>  <p>MXCMSGM</p> <p>MGAL CARBON STEEL HEC</p>	<p>SCREW ANCHOR COUPLER</p> <p>XBolt</p>  <p>MXCMSYM</p> <p>ZYP CARBON STEEL HEC</p>	<p>SCREW ANCHOR CSK HEX</p> <p>XBolt</p>  <p>MXKMSGM</p> <p>MGAL CARBON STEEL HEC</p>	<p>SCREW ANCHOR CSK HEX</p> <p>XBolt</p>  <p>MXKMSYM</p> <p>ZYP CARBON STEEL HEC</p>
<p>SCREW ANCHOR BUTTON TORX</p> <p>XBolt</p>  <p>MXDMSGM</p> <p>MGAL CARBON STEEL HEC</p>	<p>SCREW ANCHOR EYE BOLT</p> <p>XBolt</p>  <p>MXEMSYM</p> <p>ZYP CARBON STEEL HEC</p>	<p>VERTICAL HANGER SOCKET</p> <p>XBolt</p>  <p>MXSVSM</p> <p>BLUE FOR M10 XBOLT® HEC</p>	<p>NEW SCREW ANCHOR BITE INTERNAL HEX</p> <p>XBolt BITE</p>  <p>MXBMSRM</p> <p>R1000 HOURS CARBON STEEL HEC</p>

Serrated flange head for improved fixture grip.

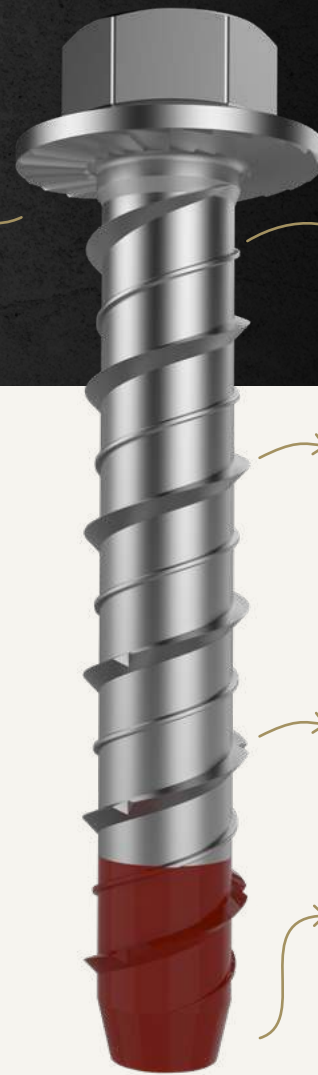

Heat-treated carbon steel for secured concrete tapping.

Optimised thread profile and pitch for easy installation and reliable performance.

Thread indentation for improved concrete tapping.

Tapered end for easier insertion into the hole.



CLAWBOLT®

Pre-assembled Through Bolt Wedge Anchors



WEDGE ANCHOR

CLAWBOLT

316



MAW16PCM

316
STAINLESS STEEL
HEC



Check out our Clawbolt® hoodies in our Merchandise at hobson.com.au



Engineered clip for reduced rotation and optimal expansion.

WEDGE ANCHOR

CLAWBOLT



MAW58GCM

MGAL
SS 304 RING
HEC / CLASS 5.8

MGAL & SS 304

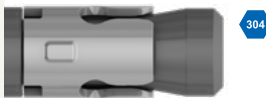

Mechanically galvanised with 304 Stainless Steel Clip.

WEDGE ANCHOR

CLAWBOLT



MAW46GCM

MGAL
SS 304 RING
HEC / CLASS 4.6

WEDGE ANCHOR

CLAWBOLT



MAW58YCM

ZYP
HEC
CLASS 5.8

WEDGE ANCHOR

CLAWBOLT





MAW46YCM



ZYP
HEC
CLASS 4.6



TY9aBolt®



Fully-assembled Sleeve Anchors

SLEEVE ANCHOR	SLEEVE ANCHOR
TY9aBolt®	TY9aBolt®
	
MTB16PM	MTBMSGM
316 STAINLESS STEEL HEC	MGAL CARBON STEEL HEC

SLEEVE ANCHOR	SLEEVE ANCHOR FLUSH HEAD
TY9aBolt®	TY9aBolt®
	
MTBMSYM	MTH16PM
ZYP CARBON STEEL HEC	316 STAINLESS STEEL HEC

NEW SLEEVE ANCHOR CSK PHILLIPS
TY9aBolt®

MTC88YM
ZYP HEC CLASS 8.8

FLUSH HEAD SLEEVE ANCHOR	NEW SLEEVE ANCHOR EYE
TY9aBolt®	TY9aBolt®
	
MTH88YM	MTEMSYM
ZYP HEC CLASS 8.8	ZYP CARBON STEEL HEC

Serrated flange nut for improved fixture grip.



Expansion claws prevent rotation during tightening.

Cold-formed cone for efficient expansion of the sleeve.



H-IT[®]

Pre-expanded Mechanical Anchors

MUSHROOM ANCHOR

H-IT

316



MHA16PMM

316
STAINLESS STEEL
HEC

MUSHROOM ANCHOR

H-IT



MHAHTMMM

MGAL
CARBON STEEL
HEC

COUNTERSUNK ANCHOR

H-IT



MHAHTMCM

MGAL
CARBON STEEL
HEC

TIE WIRE ANCHOR

H-IT



MHAHTZTM

Z/P
CARBON STEEL
HEC

MINI SPLICE WEDGE

H-IT



MHWMSZSM

Z/P
CARBON STEEL
HEC



The H-IT anchor has an s-shaped kink which compresses against the straight hole to lock the fixing in place.



TX-CON

Concrete and Timber applications

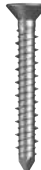
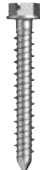

<p>FRAMING ANCHOR TORX</p>  <p>MTXSRGO</p> <p>R1000 HOURS CARBON STEEL HEC</p>	<p>SCREW ANCHOR CSK PHILLIPS</p>  <p>MTXTRCP</p> <p>R1000 HOURS CARBON STEEL HEC</p>	<p>SCREW ANCHOR HEX SLOTTED</p>  <p>MTXTRHL</p> <p>R1000 HOURS CARBON STEEL HEC</p>
--	--	---

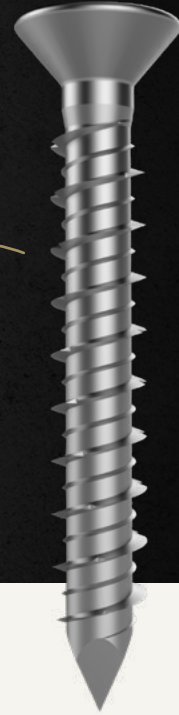
R1000 hours protective coating.



WALLKATT

Universal Light Duty Screw Anchor

<p>UNIVERSAL PAN PHILLIPS</p>  <p>MWKXZPP</p> <p>Z/P CARBON STEEL HEC</p>	<p>UNIVERSAL PAN SQUARE</p>  <p>MWKXZPQ</p> <p>Z/P CARBON STEEL HEC</p>
--	--

Special thread design prevents spinning and stripping.

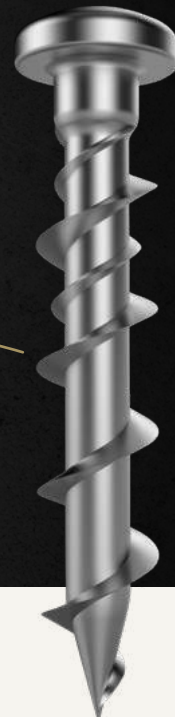



POST HEAD COUNTERSUNK INT THREAD

316



MPC16PM

316 STAINLESS STEEL HEC

Female Screw

Used as a decorative nut and installed on the protruding male thread.

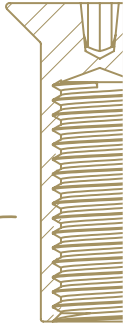

Internally threaded

VERTICAL HANGER METAL



MVMMSZIM

Z/P CARBON STEEL HEC

VERTICAL HANGER TIMBER



MVWMSZIM

Z/P CARBON STEEL HEC

VERTICAL SIDE HANGER METAL



MVMMSZSM

Z/P CARBON STEEL HEC

VERTICAL HANGER SOCKET



MXSVS-SI

BLUE USE FOR SE/INT M6 M8 M10

TIE WIRE SUSPENSION ANCHOR



MSTMSYM

ZYP CARBON STEEL HEC

SUSPENSION ANCHOR



MSAMSYM

ZYP CARBON STEEL HEC

HOLLOW WALL ANCHOR TOOL RATCHET STYLE



MATWHR

CARBON STEEL HEC

Hollow Wall Tool and Anchor

MATWHR - recommended setting tool for the hollow wall anchor MWHZPCM.



Anti-rotation barbs

HOLLOW WALL ANCHOR STANDARD



MWHZPCM

Z/P CARBON STEEL HEC

NEW SLEEVE ANCHOR COUNTERSUNK NUT



MTFHDS03

Z/P CARBON STEEL DS03 / SECURITY

NEW SLEEVE ANCHOR DOME NUT

304



MTFHDS08

304 STAINLESS STEEL DS08 / SECURITY

NEW SLEEVE ANCHOR DOME NUT



MTFHDS02

Z/P CARBON STEEL DS02 / SECURITY

NEW SLEEVE ANCHOR MUSH HEAD TORX



MTFHDSE10

Z/P CLASS 8.8 DSE10 / SECURITY

NEW RECESS PLUG TORX



MTFOLB010

Z/P SECURITY HEC

KEY

B316
BI-METAL 316 STAINLESS

ALUM
ALUMINIUM

Z/P
ZINC PLATED (RoHS COMPLIANT)

ZYP
ZINC YELLOW PASSIVATE

HDG
HOT DIP GALVANISED

MGAL
MECHANICAL GALVANISED

R10
R1000 HOURS PROTECTIVE COAT

NEW SPAGHETTI CONTINUOUS PLUG 5.5x5M



MWPSR55005

PLA HEC RED

NEW SPAGHETTI CONTINUOUS PLUG 5.0x50M



MWPSR50050

PLA HEC GREEN

NEW SPAGHETTI CONTINUOUS PLUG 5.5x50M



MWPSR55050

PLA HEC RED

Spaghetti Rolls

Continuous plugs, cut off at the required length.





1-2-3G SCREW TAPERED POINT



MWPFY

PE
HEC
YELLOW

4-5-6G SCREW TAPERED POINT



MWPFW

PE
HEC
WHITE

8-9G SCREW TAPERED POINT



MWPFRR

PE
HEC
RED

10-12G SCREW TAPERED POINT



MWPFGR

PE
HEC
GREEN

14-16G SCREW TAPERED POINT



MWPFBR

PE
HEC
BLUE

16-18G SCREW TAPERED POINT



MWPFOR

PE
HEC
ORANGE

20-24G SCREW TAPERED POINT



MWPFGR

PE
HEC
GREY

PANTHA PLUG® SUIT-8G SCREW



MWPPM

Z/P
METAL
HEC

PANTHA PLUG® SUIT-8G SCREW



MWPPP

NY PA66
HEC

UNIVERSAL WALL PLUG TAPERED POINT



MWPNUG

NYLON GREY
HEC
GREY

NEW RENDER WASHER



WRPEBRM

PE
HEC
BLUE

Render Washer

Designed to fix
insulation panels.



To be used with 10-gauge
countersunk screws.

DROP-IN SETTING TOOL



MATMSZM

Z/P
CARBON STEEL
HEC

DROP-IN SETTING TOOL WITH HANDLE



MATR

RED GRIP
CARBON STEEL
HEC

DROP-IN ANCHOR WITH LIP



MDLMSYCM

ZYP
CARBON STEEL
KNURLED BODY

DROP-IN ANCHOR WITH LIP BUCKET



MDKMSYCM

500 X M10 X 30
2 X 12MM SDS BITS
1 X HANDLE

DROP-IN ANCHOR

316



MDI16PCM

316
STAINLESS STEEL
PLAIN BODY

DROP-IN ANCHOR



MDIMSICM

ZYP
CARBON STEEL
PLAIN BODY

NAIL-IN ANCHOR MUSHROOM



MNMNM

NYLN
STEEL PIN
HEC

NAIL-IN ANCHOR MUSHROOM

304



MNMSM

NYLN & 304
STAINLESS STEEL
PIN / HEC

NAIL-IN ANCHOR ROUND



MNRNM

NYLN
STEEL PIN
HEC

NAIL-IN ANCHOR ROUND

304



MNRSM

NYLN & 304
STAINLESS STEEL
PIN / HEC

NAIL-IN ANCHOR MUSHROOM



MNPZM

Z/P
HEC
STEEL PIN

KEY

NYLN
NYLON
NATURAL

NY PA66
NYLON
POLYAMIDE PA66

PE
POLYETHYLENE

PLA
PLASTIC

STEEL
STEEL



Packing Shims



Available in carton and/or bucket

The easy solution for packing, levelling or spacing.

<p>NEW PACKING SHIMS WINDOW 1.0 - 10.0 X 75</p> <p>MPWAL075 ALUMINIUM HEC CARTON</p>	<p>NEW PACKING SHIMS WINDOW 1.0 - 10.0 X 90</p> <p>MPWAL090 ALUMINIUM HEC CARTON</p>	<p>NEW PACKING SHIMS WINDOW 1.0 - 10.0 X 140</p> <p>MPWAL140 ALUMINIUM HEC CARTON</p>				
<p>NEW PACKING SHIMS WINDOW 1.5 X 75</p> <p>MPWPL075015 PLA WHITE HEC / CARTON</p>	<p>NEW PACKING SHIMS WINDOW 3.2 X 75</p> <p>MPWPL075032 PLA BLUE HEC / CARTON</p>	<p>NEW PACKING SHIMS WINDOW 5.0 X 75</p> <p>MPWPL075050 PLA RED HEC / CARTON</p>	<p>NEW PACKING SHIMS WINDOW 6.4 X 75</p> <p>MPWPL075064 PLA GREEN HEC / CARTON</p>	<p>NEW PACKING SHIMS WINDOW 10.0 X 75</p> <p>MPWPL075100 PLA BLACK HEC / CARTON</p>	<p>NEW PACKING SHIMS WINDOW 1.5 - 10.0 X 90</p> <p>MPWPL090X PLA MIX (WHITE/BLUE/RED/GREEN/BLACK) HEC / CARTON</p>	
<p>NEW PACKING SHIMS WINDOW 1.5 X 75</p> <p>FTMPWPL075015 PLA WHITE HEC / BUCKET</p>	<p>NEW PACKING SHIMS WINDOW 3.2 X 75</p> <p>FTMPWPL075032 PLA BLUE HEC / BUCKET</p>	<p>NEW PACKING SHIMS WINDOW 5.0 X 75</p> <p>FTMPWPL075050 PLA RED HEC / BUCKET</p>	<p>NEW PACKING SHIMS WINDOW 6.4 X 75</p> <p>FTMPWPL075064 PLA GREEN HEC / BUCKET</p>	<p>NEW PACKING SHIMS WINDOW 10.0 X 75</p> <p>FTMPWPL075100 PLA BLACK HEC / BUCKET</p>	<p>NEW PACKING SHIMS WINDOW 1.5 - 10.0 X 75</p> <p>FTMPWPL075X PLA MIX HEC / BUCKET</p>	<p>NEW PACKING SHIMS WINDOW 1.5 - 10.0 X 90</p> <p>FTMPWPL090X PLA MIX HEC / BUCKET</p>



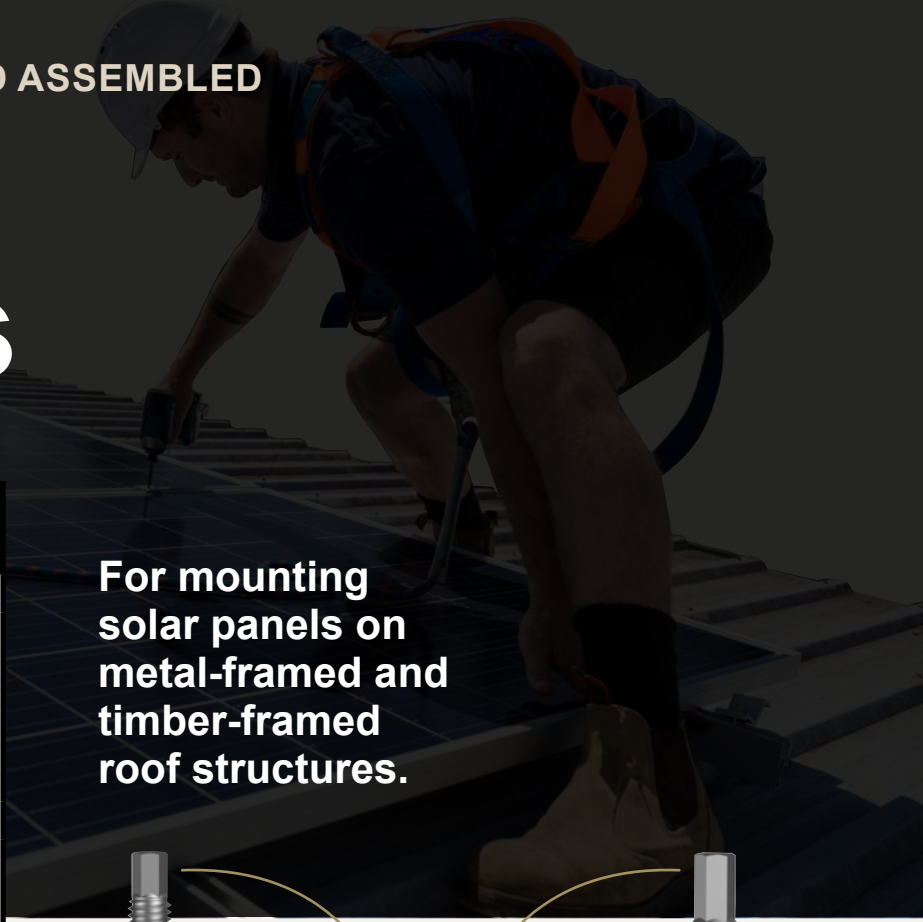

DUAL THREAD KITS SUPPLIED ASSEMBLED

Solar Screws



For mounting solar panels on metal-framed and timber-framed roof structures.

NEW DUAL THREAD SOLAR SCREW KIT	NEW DUAL THREAD SOLAR SCREW KIT	NEW DUAL THREAD SOLAR SCREW KIT
		
MTFERWA	MTFENW210	MTFENW211
304 STAINLESS STEEL RWA22	304 STAINLESS STEEL NW21	304 STAINLESS STEEL NW21

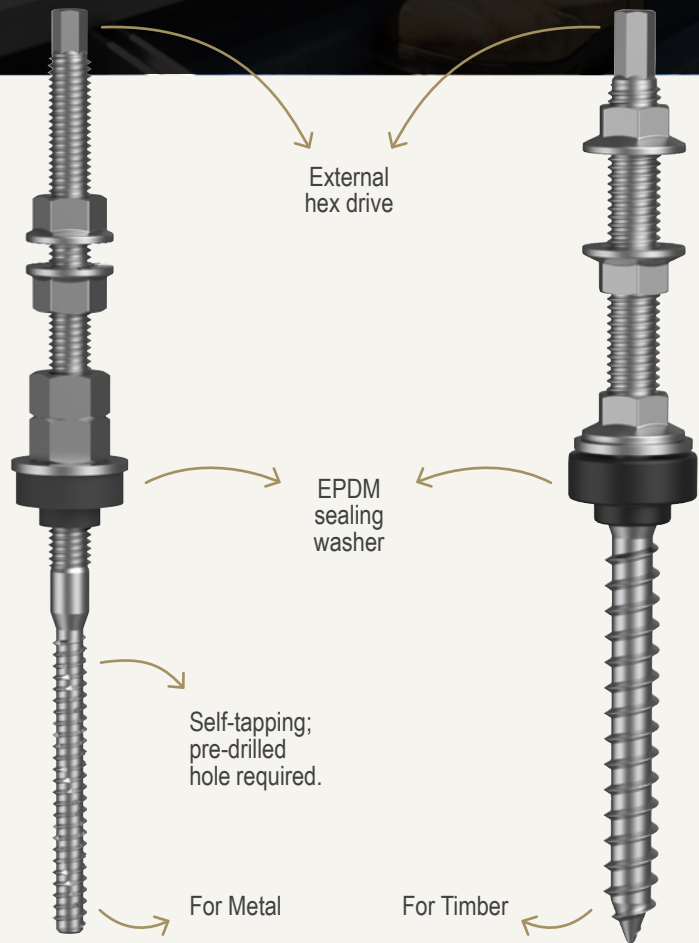



Chemical Anchors

Supplied with a nut and washer

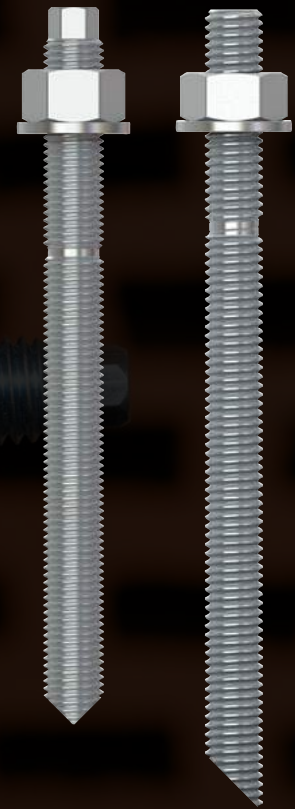

MUNGO

Suitable for chemical injection system.



CHEMICAL ANCHOR KIT EXTERNAL HEX



MCA58YCM

ZYP
CLASS 5.8
CHISEL POINT

CHEMICAL ANCHOR KIT EXTERNAL HEX



MCA58GCM

HDG
CLASS 5.8
CHISEL POINT

NEW CHEMICAL ANCHOR KIT EXTERNAL HEX



MCA88GCM

HDG
CLASS 8.8
CHISEL POINT

External Hex

An external hex drive bit is included in each pack of external hex drive stud anchors.



CHEMICAL ANCHOR KIT EXTERNAL HEX



MCA16PCM

316
STAINLESS STEEL
CHISEL POINT

CHEMICAL ANCHOR KIT FLAT TOP STUD



MCS16PCM

316
STAINLESS STEEL
ANGLE POINT

CHEMICAL ANCHOR KIT FLAT TOP STUD



MCS58GCM

HDG
CLASS 5.8
ANGLE POINT

NEW CHEMICAL ANCHOR KIT FLAT TOP STUD



MCS88GCM

HDG
CLASS 8.8
ANGLE POINT

NEW INTERNAL THREAD STUD ANCHOR



MCIMSZDM

Z/P
CARBON STEEL
ANGLE POINT

NEW INTERNAL THREAD STUD ANCHOR



MC116PDM

316
STAINLESS STEEL
ANGLE POINT

Stud Anchor

Non-expanding anchor.

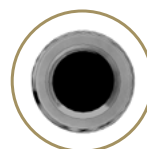

Top view



Internal thread



AS 5216 COMPLIANT

XBolt PRO

Professional Screw Anchor range

NEW SCREW ANCHOR HEX FLANGE	NEW SCREW ANCHOR HEX FLANGE	NEW SCREW ANCHOR HEX FLANGE	NEW SCREW ANCHOR CSK TORX	NEW SCREW ANCHOR DOME TORX	NEW SCREW ANCHOR STUD	NEW SCREW ANCHOR STUD
XBolt PRO	XBolt PRO	XBolt PRO	XBolt PRO	XBolt PRO	XBolt PRO	XBolt PRO
EXHMSR15M	EXHMSR18M	EXH6XP15M	EXK6XP15M	EXD6XP15M	EXSMSZD15M	EXSMSZD18M
R1000 HOURS ETA OPT 1 FIRE RATED	R1000 HOURS ETA OPT 1 / C1 C2 FIRE RATED	BI-METAL 316 SS ETA OPT 1 FIRE RATED	BI-METAL 316 SS ETA OPT 1 FIRE RATED	BI-METAL 316 SS ETA OPT 1 FIRE RATED	Z/P ETA OPT 1 FIRE RATED	Z/P ETA OPT 1 / C1 C2 FIRE RATED

AS 5216 COMPLIANT

CLAWBOLT PRO

Professional Wedge Anchor range





NEW WEDGE ACHOR	NEW WEDGE ACHOR	NEW WEDGE ACHOR	NEW WEDGE ACHOR	NEW WEDGE ACHOR	NEW WEDGE ACHOR	NEW WEDGE ACHOR
CLAWBOLT PRO	CLAWBOLT PRO	CLAWBOLT PRO	CLAWBOLT PRO	CLAWBOLT PRO	CLAWBOLT PRO	CLAWBOLT PRO
EAWMSZD15M	EAWMSGD15M	EAWMSZD17M	EAWMSZD18M	EAW16PD17M	EAW16PD18M	EAW16PD70M
Z/P ETA OPT 1 FIRE RATED	MGAL ETA OPT 1 FIRE RATED	Z/P ETA OPT 1 / C1 FIRE RATED	Z/P ETA OPT 1 / C1 C2 FIRE RATED	316 SS ETA OPT 1 / C1 FIRE RATED	316 SS ETA OPT 1 / C1 C2 FIRE RATED	316 SS ETA OPT 7 A4



AS 5216 COMPLIANT

DROP-IN PRO

Professional Drop-In Anchor range

<p>NEW DROP-IN PRO ANCHOR</p> <p>DROP-IN PRO</p>  <p>EDIMSZ73M</p> <p>Z/P ETA OPT 7 PART 6</p>	<p>NEW DROP-IN PRO ANCHOR</p> <p>DROP-IN PRO</p>  <p>EDIMSZ76M</p> <p>Z/P ETA OPT 7 / PART 6 FIRE RATED</p>	<p>NEW DROP-IN PRO ANCHOR WITH LIP</p> <p>DROP-IN PRO</p>  <p>EDLMSZ73M</p> <p>Z/P ETA OPT 7 PART 6</p>	<p>NEW DROP-IN PRO ANCHOR WITH LIP</p> <p>DROP-IN PRO</p>  <p>EDLMSZ76M</p> <p>Z/P ETA OPT 7 / PART 6 FIRE RATED</p>	<p>NEW DROP-IN PRO SETTING TOOL</p> <p>DROP-IN PRO</p>  <p>EDTMSZM</p> <p>ETA USE WITH EDIMSZ & EDLMSZ</p>
---	--	--	---	--

AS 5216 COMPLIANT

H-IT[®] PRO

Professional Splice Wedge Anchor

NEW SPICE WEDGE ANCHOR

H-IT PRO



EHWMSZS37M

Z/P
ETAG 001 / PART 6
FIRE RATED

How to download ETA:



Click and download ETA from this logo in the Product Documents list at hobson.com.au

KEY



- ETA -

European Technical Assessment
Directly compatible with AS 5216



- Fire Rated -

Assessment of Resistance
Under Fire Exposure



- Category C1
and/or C2 -

Seismic Load Approval
Performance

DRILLXX





DRILLX[®]



METAL

<p>METAL SDS FLANGED HEX</p>  <p>T9PM3FH</p> <p>CLASS 3 AS3566</p>	<p>METAL SDS FLANGED HEX</p>  <p>T9PMYFH</p> <p>ZYP AS3566</p>	<p>METAL SDS FLANGED HEX</p>  <p>T9PMZFH</p> <p>Z/P AS3566</p>	
<p>METAL SDS FLANGED HEX</p>  <p>T9PM4FH</p> <p>CLASS 4 AS3566</p>	<p>METAL SDS FLANGED HEX 5/16AF</p>  <p>T9PM3RH</p> <p>CLASS 3 AS3566</p>	<p>METAL SDS FLANGED HEX + SEAL WASHER</p>  <p>T9PM4SH</p> <p>CLASS 4 AS3566</p>	<p>EPDM SEAL WASHER FLUTED</p>  <p>TXW9PEFS</p> <p>PLAIN</p>
<p>METAL SDS FLANGED HEX + SEAL WASHER</p>  <p>T9PM4SS</p> <p>CLASS 4 AS3566</p>	<p>METAL SDS FLANGED HEX + SEAL WASHER</p>  <p>T9PM4XS</p> <p>CLASS 4 AS3566</p>	<p>METAL SDS FLANGED HEX + SEAL WASHER</p>  <p>T9PM4XH</p> <p>CLASS 4 AS3566</p>	<p>METAL SDS FLANGED HEX</p>  <p>T9PM4FS</p> <p>CLASS 4 AS3566</p>

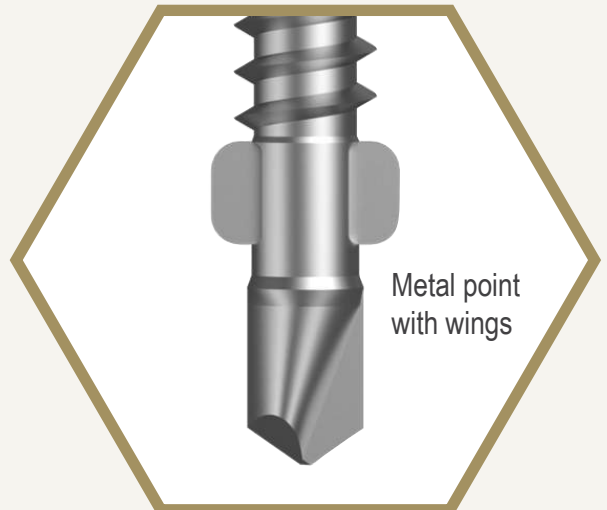



NEW METAL SDS WAFER PHILLIPS



T9PMYWP

ZYP
AS3566

METAL SDS BUGLE BATTEN RIBBED SQUARE



T9PM3BQ

CLASS 3
AS3566

NEW METAL SDS BUGLE PHILLIPS



FLT9PMLBP

B-PH
AS3566

Collated screws



To be used with all auto-feed collated screw guns.

METAL SDS MINI LOW-PROFILE PHILLIPS



T9PM3MP

CLASS 3
AS3566

NEW METAL SDS FLAT SQUARE



T04MSLQ

304
STAINLESS STEEL
USE WITH ALUM

NEW METAL SERRATED FLAT FRAMING PHILLIPS



T9PMKEP

E-COAT
BLACK
AS3566

NEW METAL SUPER FLAT FRAMING PHILLIPS



T9PMKNP

E-COAT
BLACK
AS3566

METAL SDS CSK PHILLIPS



T9PMYCP

ZYP
AS3566

METAL SDS CSK PHILLIPS



T9PM3CP

CLASS 3
AS3566

METAL SDS CSK RIBBED PHILLIPS



T9PMYRP

ZYP
AS3566

METAL SDS CSK RIBBED PHILLIPS

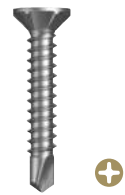

T9PM3RP

CLASS 3
AS3566

METAL SDS PAN PHILLIPS



T9PMYPP

ZYP
AS3566

METAL SDS BUGLE PHILLIPS



T9PMYBP

ZYP
AS3566

METAL SDS BUGLE PHILLIPS

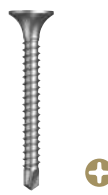

T9PMZBP

Z/P
AS3566

METAL SDS BUGLE BATTEN RIBBED INTERNAL HEX



T9PM3BH

CLASS 3
AS3566

METAL SDS WAFER PHILLIPS

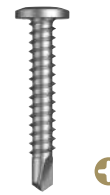

T9PM3WP

CLASS 3
AS3566

METAL SDS BUGLE PHILLIPS

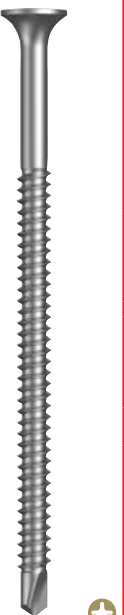

T9PM3BP

CLASS 3
AS3566

METAL SDS BUTTON WAFER PHILLIPS



T9PMYAP

ZYP
AS3566

METAL SDS BUTTON WAFER PHILLIPS

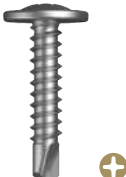

T9PM3AP

CLASS 3
AS3566

METAL SDS FLAT PHILLIPS



T9PMYLP

ZYP
AS3566

METAL SDS FLAT PHILLIPS



T9PM3LP

CLASS 3
AS3566

METAL SDS FLOWER SELF-EMBED PHILLIPS



T9PMYOP

ZYP
AS3566

METAL SDS PAN TRILOBULAR



T9PM3PI

CLASS 3
AS3566



METAL

METAL WINGS
FLOWER
SELF-EMBED
SQUARE



T9PGYOQ

ZYP
AS3566

METAL WINGS
CSK RIBBED
SQUARE



T9PG3RQ

CLASS 3
AS3566

METAL WINGS
CSK
SELF-EMBED
INTERNAL HEX



T9PG3SI

CLASS 3
AS3566

METAL WINGS
CSK RIBBED
SQUARE

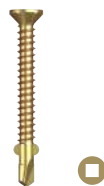

T9PGYRQ

ZYP
AS3566

S500 WINGS
CSK RIBBED
PHILLIPS



T9PHYRP

ZYP
AS3566

S500 SDS
FLANGED HEX

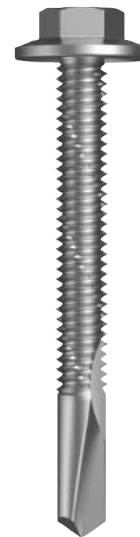

T9P54FH

CLASS 4
AS3566

S500 SDS
FLANGED HEX
+ SEAL WASHER

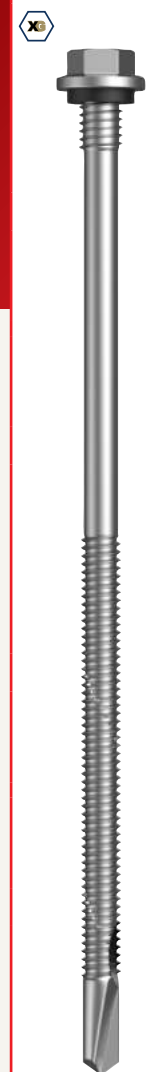

T9P54XH

CLASS 4
AS3566

NEW METAL
SDS HEX POLY
ALL-IN-1



T9PM4PA

CLASS 4
AS3566

Expansion
hole cutter

All in 1 Polycarbonate Roofing Screw



Sealing
washer

S500 SDS
FLANGED HEX
+ SEAL WASHER



T9P54SH

CLASS 4
AS3566

S500 SDS
WAFFER
PHILLIPS



T9P53WP

CLASS 3
AS3566

METAL SDS
CYCLONE
MULTISEAL



T9PM4YM

CLASS 4
AS3566

S500 SDS
CYCLONE
MULTISEAL



T9P54YM

CLASS 4
AS3566

CYCLONE MULTISEAL
WASHER

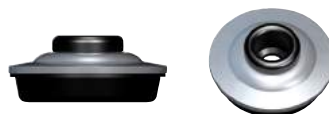

TXW9PYM

PLAIN
SUIT #14 SCREW

Colorbond®

Cyclone washer is
available in Colorbond®
range of colours p.163





Screw Terminology

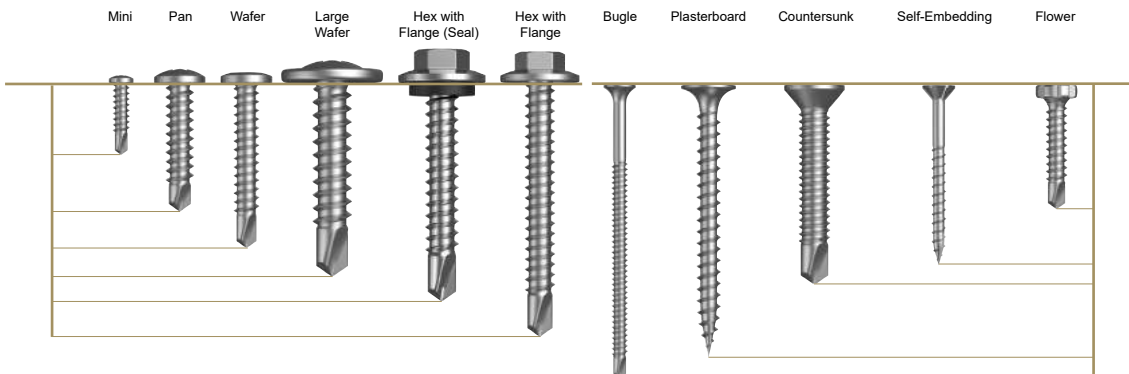
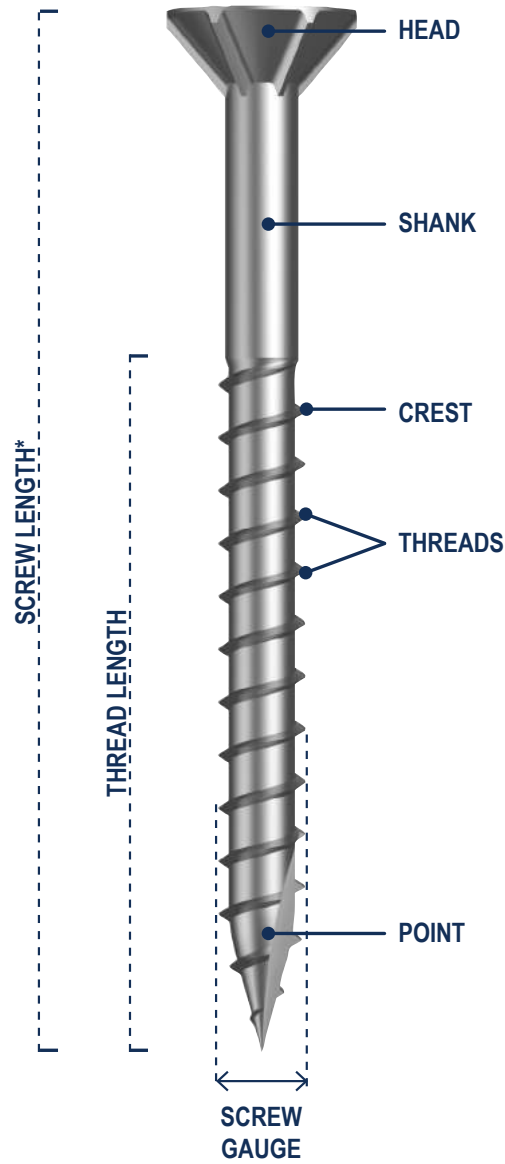

*SCREW TYPES TO MEASURE FROM THE UNDERSIDE OF THE HEAD

*SCREW TYPES TO MEASURE FROM THE TOP OF THE HEAD

KEY

Z/P
ZINC PLATED
(RoHS COMPLIANT)

ZYP
ZINC YELLOW
PASSIVATE

B-PH
BLACK
PHOSPHATE

CL3
CLASS 3

CL4
CLASS 4

R10
R1000 HOURS
PROTECTIVE COAT

ZP BLK
ZINC BLACK
PASSIVATE

TYK
TYKOTE

E-BLK
E-COAT BLACK

PLN
PLAIN

ALLOY
ALLOY STEEL

S2A
S2 ALLOY STEEL

S2B
S2 ALLOY STEEL
BLACK

S2T
S2 ALLOY STEEL
TITAN

ALUM
ALUMINIUM



Bi-FIX®

METAL SDS HEX HEAD

304 **Bi-FIX**



T4MXHH

BI-METAL
304 STAINLESS STEEL

METAL SDS PAN PHILLIPS

304 **Bi-FIX**



T4XMPP

BI-METAL
304 STAINLESS STEEL

METAL SDS PAN SQUARE

304 **Bi-FIX**



T4MXPQ

BI-METAL
304 STAINLESS STEEL

METAL SDS WAFER PHILLIPS

304 **Bi-FIX**



T4MXWP

BI-METAL
304 STAINLESS STEEL

METAL WINGS CSK RIBBED SQUARE

304 **Bi-FIX**

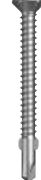

T4XGXRQ

BI-METAL
304 STAINLESS STEEL

S500 WINGS CSK RIBBED SQUARE

304 **Bi-FIX**



T4XHRQ

BI-METAL
304 STAINLESS STEEL

S500 SDS FLANGED HEX

304 **Bi-FIX**



T4X5XFH

BI-METAL
304 STAINLESS STEEL

METAL SDS ALUMINIUM SEAL HEX

304 **Bi-FIX**



T4MXAH

BI-METAL
304 STAINLESS STEEL

NEW METAL SDS HEX HEAD

316 **Bi-FIX**



T6MXHH

BI-METAL
316 STAINLESS STEEL

METAL SDS WAFER SQUARE

316 **Bi-FIX**



T6MXWQ

BI-METAL
316 STAINLESS STEEL

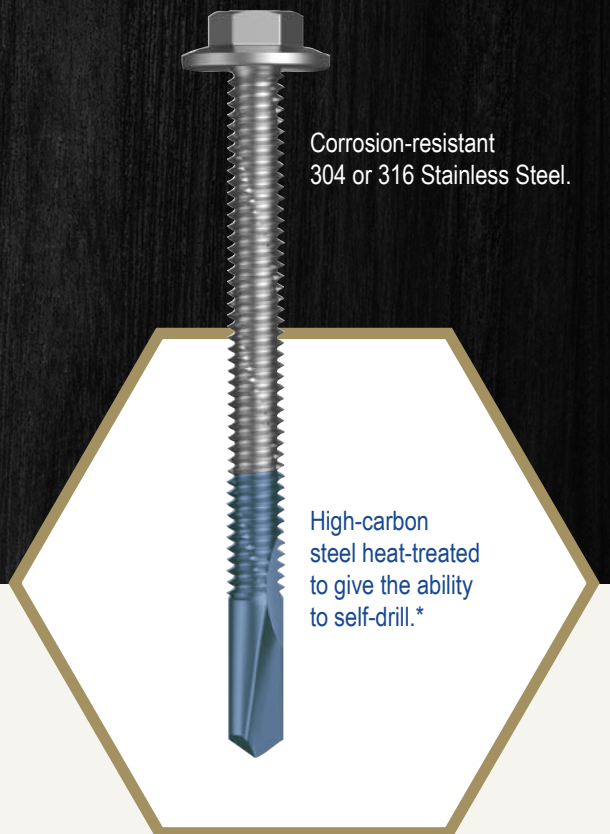

Corrosion-resistant
304 or 316 Stainless Steel.

High-carbon
steel heat-treated
to give the ability
to self-drill.*

*Point colour for illustration purposes only.

A bi-metallic screw is comprised of two metal types. The point is manufactured from high-carbon steel that is heat-treated to give it the ability to self-drill. The head section is made from a corrosion-resistant stainless steel (304 or 316). The two metals are 'fused' to form a screw that offers excellent self-drilling properties, combined with exceptional corrosion resistance.



vmaX®

SDS TRIM HEAD TORX

304 **vmaX**

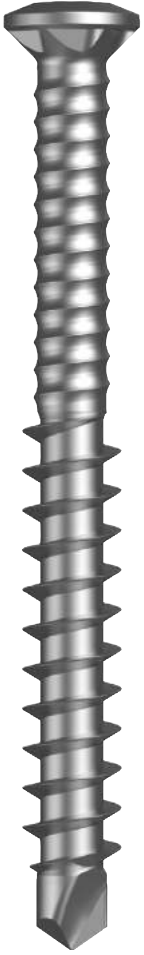

T04VSTT

304
STAINLESS STEEL

SDS FLANGED HEX + SEAL WASHER

vmaX

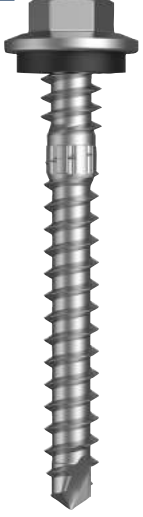

T9PV4XS

CLASS 4
AS3566

SDS BATTEN FLANGED HEX

vmaX



T9PV3FH

CLASS 3
AS3566

SDS FLANGED HEX + SEAL WASHER

vmaX



T9PV4SH

CLASS 4
AS3566



vmaX® feature a universal drilling point and are suitable for fastening roof sheeting to thin metal battens, timber trusses and steel purlins up to 1.9mm thick.



TIMBER

<p>TYPE 17 CSK RIBBED SQUARE</p> <p>304</p>  <p>T04WS6Q</p> <p>304 STAINLESS STEEL</p>	<p>TYPE 17 BUGLE BATTEN RIBBED INTERNAL HEX</p> <p>304</p>  <p>T04WSBH</p> <p>304 STAINLESS STEEL</p>	<p>NEW TYPE 17 PAN POZI</p> <p>304</p>  <p>T04WSPZ</p> <p>304 STAINLESS STEEL</p>	<p>NEW TYPE 17 FLANGED HEX 5/16AF PIT SCREW</p> <p>304</p>  <p>T04WSRH</p> <p>304 STAINLESS STEEL</p>	<p>TYPE 17 TRIM RIBBED SQUARE</p>  <p>T04WSTQ</p> <p>304 STAINLESS STEEL</p>	<p>TYPE 17 BUGLE BATTEN RIBBED INTERNAL HEX</p> <p>316</p>  <p>T16WSBH</p> <p>316 STAINLESS STEEL</p>	<p>TYPE 17 BUGLE BATTEN RIBBED SQUARE</p> <p>316</p>  <p>T16WSBQ</p> <p>316 STAINLESS STEEL</p>
<p>TYPE 17 TRIM RIBBED SQUARE</p> <p>304</p>  <p>T04WSTD</p> <p>304 STAINLESS STEEL</p>	<p>TDX®</p> <p>Trim head for a neat finish and No.1 square drive to prevent bit cam out.</p> <p>Square thread for greater holding power, preventing the deck from lifting.</p> 		<p>TYPE 17 TRIM RIBBED SQUARE</p> <p>304</p>  <p>T04WSTQ</p> <p>304 STAINLESS STEEL</p>	<p>TYPE 17 BUGLE BATTEN RIBBED INTERNAL HEX</p> <p>316</p>  <p>T16WSBH</p> <p>316 STAINLESS STEEL</p>	<p>TYPE 17 BUGLE BATTEN RIBBED SQUARE</p> <p>316</p>  <p>T16WSBQ</p> <p>316 STAINLESS STEEL</p>	
<p>TYPE 17 FLANGED HEX</p> <p>316</p>  <p>T16WSFH</p> <p>316 STAINLESS STEEL</p>	<p>TYPE 17 FLANGED HEX + SEAL WASHER</p> <p>316</p>  <p>T16WSSH</p> <p>316 STAINLESS STEEL</p>	<p>TYPE 17 SELF-EMBED SQUARE</p> <p>316</p>  <p>T16WSSQ</p> <p>316 STAINLESS STEEL</p>	<p>TYPE 17 BUTTON SQUARE</p> <p>316</p>  <p>T16WSUQ</p> <p>316 STAINLESS STEEL</p>	<p>NEW TYPE 17 WAFFER PHILLIPS</p> <p>316</p>  <p>T16WSPW</p> <p>316 STAINLESS STEEL</p>	<p>TYPE 17 BUGLE BATTEN RIBBED INTERNAL HEX</p>  <p>T9PW3BH</p> <p>CLASS 3 AS3566</p>	<p>TYPE 17 CSK PHILLIPS</p>  <p>T9PW3CP</p> <p>CLASS 3 AS3566</p>



TYPE 17 FLANGED HEX

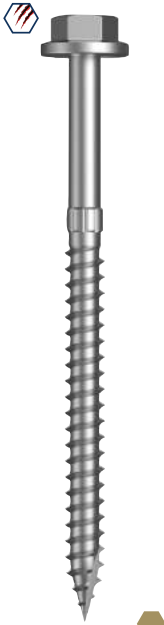

T9PW3FS

CLASS 3
AS3566

Scratchguard®

This design feature improves resistance to corrosion by protecting the fastener shank from severe scratching or scouring, which can occur when fixing metal roofing.

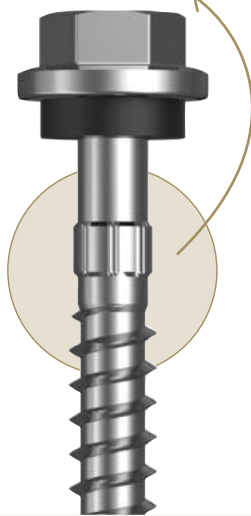

TYPE 17 WASHER HEAD INTERNAL HEX



T9PW3GI

CLASS 3
AS3566

TYPE 17 WAFFER PHILLIPS

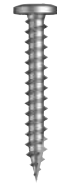

T9PW3WP

CLASS 3
AS3566

NEW TYPE 17 BUGLE BATTEN RIBBED

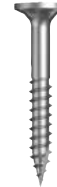

T9PW4BH

CLASS 4
AS3566

TYPE 17 FLANGED HEX

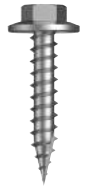

T9PW4FH

CLASS 4
AS3566

TYPE 17 FLANGED HEX

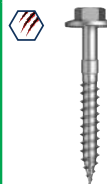

T9PW4FS

CLASS 4
AS3566

NEW TYPE 17 HEX POLY ALL-IN-1



T9PW4PA

CLASS 4
AS3566

TYPE 17 FLANGED HEX + SEAL WASHER

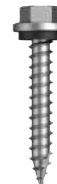

T9PW4SH

CLASS 4
AS3566

TYPE 17 FLANGED HEX + SEAL WASHER

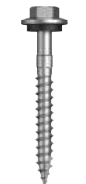

T9PW4SS

CLASS 4
AS3566

TYPE 17 FLANGED HEX + SEAL WASHER

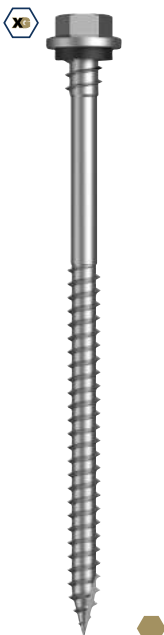

T9PW4XH

CLASS 4
AS3566

XGRIP®

A feature used to hold the roofing tight against the seal, ensuring a watertight seal even when the roof is walked upon.

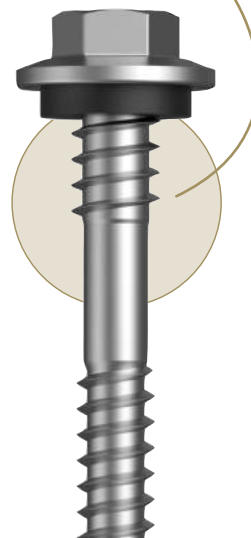

TYPE 17 FLANGED HEX + SEAL WASHER



T9PW4XS

CLASS 4
AS3566

TYPE 17 CYCLONE MULTISEAL



T9PW4YM

CLASS 4
AS3566

TYPE 17 WASHER HEAD INTERNAL HEX

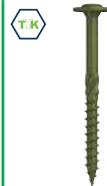

T9PWTGI

TYKOTE
HEC

TYPE 17 WASHER HEAD TORX

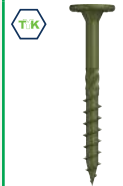

T9PWTGO

TYKOTE
HEC

TYPE 17 BUGLE BATTEN RIBBED INTERNAL HEX

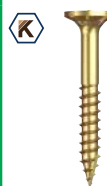

T9PWYBH

ZYP
AS3566

TYPE 17 CSK PHILLIPS



T9PWYCP

ZYP
AS3566

TYPE 17 FLANGED HEX

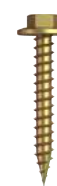

T9PWYFH

ZYP
AS3566

TYPE 17 PAN PHILLIPS



T9PWYPP

ZYP
AS3566



MULTI-USE

NEEDLE POINT CSK RIBBED SQUARE



T04NS4Q

304
STAINLESS STEEL

TREATED PINE SELF-EMBED SQUARE



T9PD3SQ

CLASS 3
AS3566

CHIPBOARD CSK RIBBED PHILLIPS



T9PDYRP

ZYP
AS3566

NEEDLE POINT BUTTON SQUARE



T04NSUQ

304
STAINLESS STEEL

NEW NEEDLE POINT BUGLE PLASTERBOARD PHILLIPS



FLT9PCLBP

B-PH
AS3566
COARSE

Collated screws

To be used with all auto-feed collated screw guns.

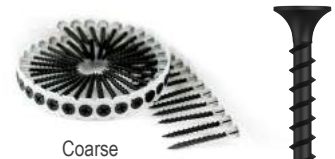

Coarse



Fine

NEEDLE POINT LARGE WAFER METAL STITCH PHILLIPS

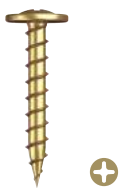

T9PCYAP

ZYP
AS3566
COARSE

NEEDLE POINT BUGLE PLASTERBOARD PHILLIPS

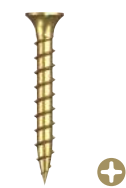

T9PCYBP

ZYP
AS3566
COARSE

NEEDLE POINT LARGE WAFER METAL STITCH PHILLIPS

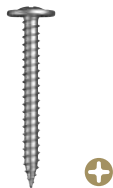

T9PN3AP

CLASS 3
AS3566

TYPE A BUTTON POST TORX



T9PA3BT

CLASS 3
AS3566

NEW NEEDLE POINT BUGLE PLASTERBOARD PHILLIPS



FLT9PNLBP

B-PH
AS3566

NEEDLE POINT FLAT PHILLIPS



T9PN3LP

CLASS 3
AS3566

NEEDLE POINT FLANGED HEX METAL STITCH



T9PN4FH

CLASS 4
AS3566

NEEDLE POINT FLANGED HEX + SEAL WASHER METAL STITCH



T9PN4SH

CLASS 4
AS3566

NEEDLE POINT LARGE WAFER METAL STITCH PHILLIPS

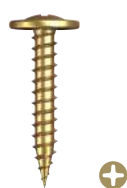

T9PNYAP

ZYP
AS3566

NEEDLE POINT BUGLE PLASTERBOARD PHILLIPS

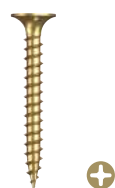

T9PNYBP

ZYP
AS3566

NEEDLE POINT FLAT PHILLIPS



T9PNYLP

ZYP
AS3566

NEEDLE POINT SELF-EMBED PHILLIPS

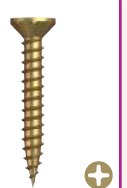

T9PNYSP

ZYP
AS3566



Framing Screws

**NEW
SERRATED
FLAT FRAMING
PHILLIPS**



T9PFKEP

E-COAT
BLACK
AS3566

**NEW METAL
SERRATED
FLAT FRAMING
PHILLIPS**



T9PMKEP

E-COAT
BLACK
AS3566

**NEW METAL
SUPER
FLAT FRAMING
PHILLIPS**



T9PMKNP

E-COAT
BLACK
AS3566

**NEEDLE POINT
FLAT
PHILLIPS**



T9PN3LP

CLASS 3
AS3566

**NEEDLE POINT
FLAT
PHILLIPS**



T9PNYLP

ZYP
AS3566

**METAL SDS
FLAT
PHILLIPS**



T9PMYLP

ZYP
AS3566

**TRUSS
FRAMING
FLANGED HEX**



T9PF3FH

CLASS 3
HEC

**HVAC BLUNT
POINT WASHER
HEX**



T9PFZWH

Z/P
HEC



Extended thread to the tip of the point allows easy start and alignment.



jmax™

Engineered point for self-drilling and fixing metal plate to timber without splitting.

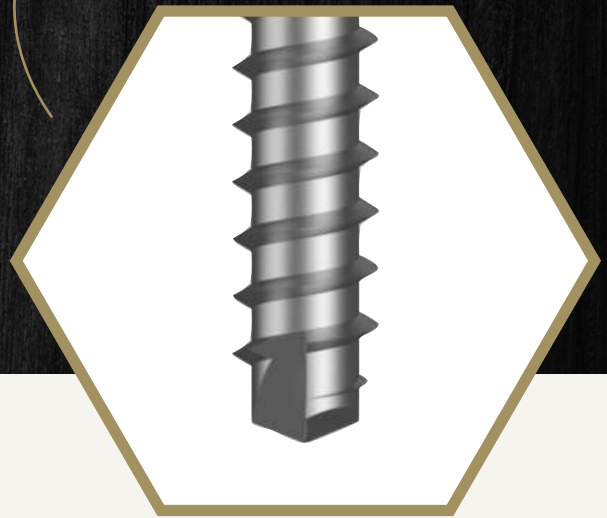

SDS FLANGED HEX
jmax

T9PJ3FH1410030
 CLASS 3
 AS3566
 YELLOW

SDS FLANGED HEX
jmax

T9PJ3FH1410065
 CLASS 3
 AS3566
 BLUE

ALL-IN-1

Polycarb Assemblies

NEW METAL SDS HEX POLY ALL-IN-1

T9PM4PA
 CLASS 4
 AS3566

NEW TYPE 17 HEX POLY ALL-IN-1

T9PW4PA
 CLASS 4
 AS3566

Large domed sealing washer to support and seal polycarbonate roofing.



Head

Cutter



Expansion hole cutter creates a thermal expansion hole in the roofing sheet.



TYKOTE[®]

**TYPE 17
WASHER HEAD
INTERNAL HEX**

TYKOTE.



T9PWTGI

TYKOTE
HEC



**TYPE 17
WASHER HEAD
TORX**

TYKOTE.



T9PWTGO

TYKOTE
HEC







A high-performance coating specially formulated for resisting treated pine chemicals.



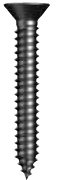
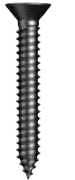

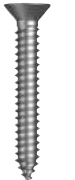
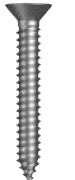
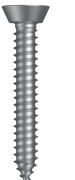
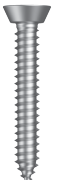
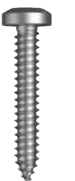
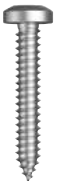



















Self-Tapping Screws

<p>SELF-TAPPER CSK PHILLIPS</p>  <p>T9PSVCP</p> <p>ZP BLK ANSI B18.6.4 TYPE AB</p>	<p>SELF-TAPPER CSK SQUARE</p>  <p>T9PSVCQ</p> <p>ZP BLK ANSI B18.6.4 TYPE AB</p>	<p>SELF-TAPPER PAN PHILLIPS</p>  <p>T9PSVPP</p> <p>ZP BLK ANSI B18.6.4 TYPE AB</p>	<p>SELF-TAPPER PAN SQUARE</p>  <p>T9PSVPQ</p> <p>ZP BLK ANSI B18.6.4 TYPE AB</p>
<p>SELF-TAPPER CSK PHILLIPS</p>  <p>T9PSZCP</p> <p>Z/P ANSI B18.6.4 TYPE AB</p>	<p>SELF-TAPPER CSK SQUARE</p>  <p>T9PSZCQ</p> <p>Z/P ANSI B18.6.4 TYPE AB</p>	<p>SELF-TAPPER UNDERCUT CSK PHILLIPS</p>  <p>T9PSZDP</p> <p>Z/P ANSI B18.6.4 TYPE AB</p>	<p>SELF-TAPPER UNDERCUT CSK SQUARE</p>  <p>T9PSZDQ</p> <p>Z/P ANSI B18.6.4 TYPE AB</p>
<p>SELF-TAPPER PAN PHILLIPS</p>  <p>T9PSZPP</p> <p>Z/P ANSI B18.6.4 TYPE AB</p>	<p>SELF-TAPPER PAN SQUARE</p>  <p>T9PSZPQ</p> <p>Z/P ANSI B18.6.4 TYPE AB</p>	<p>ELECTRICAL PANEL SCREW PHILLIPS</p>  <p>T9PPZAP</p> <p>Z/P HEC</p>	

SCREW HEAD & SEAL STYLES

Head	Seal Style	Head	Seal Style
	Hex Flange Head		Wafer
	Countersunk		Button Head
	Countersunk Ribbed		Flat Head
	Undercut Countersunk		Flat Serrated
	Bugle		Washer Head
	Bugle Batten Ribbed		Large Washer Head
	Trim Head Ribbed		Flower
	Pan Head		Hex Head with Seal
	Mini Pan		Hex Head with EPDM Seal
	Large Wafer		Hex Head with Multiseal



DECK MASTER®



BRANDS

Find the NEW Deck Master range in our Brands section at hobson.com.au



A range of screws that suit all decking applications in any environment.

METAL SDS BUGLE BATTEN RIBBED INTERNAL HEX

T9PM3BH

CLASS 3
AS3566

METAL WINGS CSK RIBBED SQUARE

T9PG3RQ

CLASS 3
AS3566

METAL SDS BUGLE BATTEN RIBBED SQUARE

T9PM3BQ

CLASS 3
AS3566

SDS WINGS CSK RIBBED SQUARE

T4XGXRQ

304
STAINLESS STEEL

S500 WINGS CSK RIBBED SQUARE

T4XHRQ

304
STAINLESS STEEL

SDS TRIM HEAD TORX

T04VSTT

304
STAINLESS STEEL

TYPE 17 TRIM RIBBED SQUARE

T04WSTD

304
STAINLESS STEEL

TYPE 17 CSK RIBBED SQUARE

T04WS6Q

304
STAINLESS STEEL

TYPE 17 TRIM RIBBED SQUARE

T04WSTQ

304
STAINLESS STEEL

TYPE 17 BUGLE BATTEN RIBBED INTERNAL HEX

T04WSBH

304
STAINLESS STEEL

TYPE 17 BUGLE BATTEN RIBBED SQUARE

T16WSBQ

316
STAINLESS STEEL

TYPE 17 BUGLE BATTEN RIBBED INTERNAL HEX

T16WSBH

316
STAINLESS STEEL

TYPE 17 SELF-EMBED SQUARE

T16WSSQ

316
STAINLESS STEEL

TYPE 17 BUGLE BATTEN RIBBED INTERNAL HEX

T9PW3BH

CLASS 3
AS3566

TYPE 17 BUGLE BATTEN RIBBED INTERNAL HEX

T9PWYBH

ZYP
AS3566

TYPE 17 WASHER HEAD INTERNAL HEX

T9PW3GI

CLASS 3
AS3566

NEEDLE POINT CSK RIBBED SQUARE

T04NS4Q

304
STAINLESS STEEL

TREATED PINE SELF-EMBED SQUARE

T9PD3SQ

CLASS 3
AS3566

CHIPBOARD CSK RIBBED PHILLIPS

T9PDYRP

ZYP
AS3566



DRILLX[®]



Colorbond[®]

Hobson Screws, Rivets
and Cyclone Washers
with painted heads
in the Colorbond[®]
range of colours.



T9PM4FH1016016
PLAIN HEAD

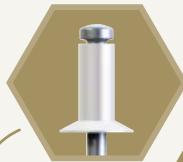

Also in the rivet
and cyclone washer
ranges.



Painted Heads

To find a rivet or screw in
any of the colours below,
simply replace the **9P** in
the part number with the
colour **Code** in the table.



TDWM4FH1016016
DOVER WHITE HEAD



COLORBOND® COLOUR MATRIX

Code	Colour Name	Colour	Code	Colour Name	Colour
DW	Dover White™		NS	Night Sky®	NZ EBONY
SM	Surfmist®	NZ TITANIA	IS	Ironstone®	
EH	Evening Haze®		DO	Deep Ocean®	NZ STORM BLUE
CC	Classic Cream™	NZ SMOOTH CREAM	CG	Cottage Green®	NZ PERMANENT GREEN
PA	Paperbark®		PE	Pale Eucalypt®	NZ MIST GREEN
CO	Cove®		TE	Terrain®	
DU	Dune®		MR	Manor Red®	NZ SCORIA
SO	Southerly®		↓ Discontinued Colours ↓ Screws painted upon request		
SG	Shale Grey™	NZ GULL GREY	BU	Bushland®	
BG	Bluegum®		WI	Wilderness®	NZ RIVERGUM
WN	Windspray®	NZ SMOKEY	LO	Loft®	
MA	Mangrove®		HE	Headland®	NZ MAPLE
GU	Gully®		SA	Sandbank®	NZ STRAW
JA	Jasper®	NZ SORRELL	PT	Pale Terracotta™	
WA	Wallaby®		BR	Blue Ridge®	NZ PACIFIC BLUE
BA	Basalt®		PL	Plantation®	
WG	Woodland Grey®	NZ THUNDER GREY	PR	Primrose™	
MO	Monument®		ST	Stone®	NZ RIVERSAND

NZ colours available on request.

*Colours are representative only.

Colorbond® is a registered trademark of BlueScope Steel Limited.





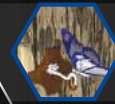

impaX[®]



Find security socket bits in **STAINLESS FASTENERS** category.



<p>INSERT HEX</p> <p>impaX</p>  <p>TXDIIHX</p> <p>DRIVE BIT 1/4 S2 ALLOY STEEL BLACK</p>	<p>INSERT PHILLIPS</p> <p>impaX</p>  <p>TXDIIPH</p> <p>DRIVE BIT 1/4 S2 ALLOY STEEL BLACK</p>	<p>INSERT SQUARE</p> <p>impaX</p>  <p>TXDIISQ</p> <p>DRIVE BIT 1/4 S2 ALLOY STEEL BLACK</p>	<p>POWER HEX</p> <p>impaX</p>  <p>TXDIPHX</p> <p>DRIVE BIT 1/4 S2 ALLOY STEEL BLACK</p>	<p>POWER PHILLIPS</p> <p>impaX</p>  <p>TXDIPPH</p> <p>DRIVE BIT 1/4 S2 ALLOY STEEL BLACK</p>
---	--	--	--	--

Drive bits designed for high-impact forces of modern power tools.





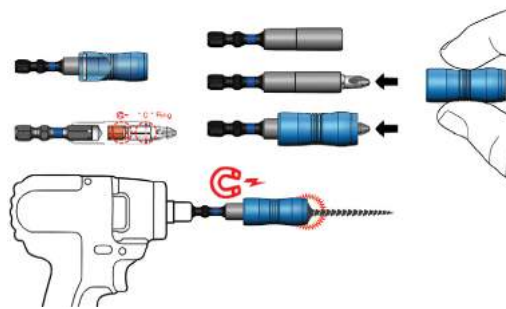



<p>MAGNETIC NUT SETTER</p> <p>impaX</p>  <p>TXDIPNS</p> <p>DRIVE BIT 1/4 S2 ALLOY STEEL BLACK</p>	<p>INSERT BIT HOLDER</p> <p>impaX</p>  <p>TXDIIBH</p> <p>DRIVE BIT 1/4 S2 ALLOY STEEL BLACK</p>	<p>INSERT BIT HOLDER MAG COLLAR</p> <p>impaX</p>  <p>TXDIIBM</p> <p>DRIVE BIT 1/4 S2 ALLOY STEEL BLACK</p>
---	---	--

Mag Collar



<p>POWER SQUARE</p> <p>impaX</p>  <p>TXDIPSQ</p> <p>DRIVE BIT 1/4 S2 ALLOY STEEL BLACK</p>	<p>POWER TORX</p> <p>impaX</p>  <p>TXDIPTX</p> <p>DRIVE BIT 1/4 S2 ALLOY STEEL BLACK</p>	<p>SDS PLUS ADAPTOR</p> <p>impaX</p>  <p>TXDIPAI</p> <p>DRIVE BIT 1/4 CHROME PLATED MATT FINISH</p>
--	--	---



KEY	
	PHILLIPS
	HEX INT
	HEX EXT
	SQUARE
	TORX
	SLOTTED
	TRIOBULAR
	SDS-PLUS
	SDS-MAX



<p>INSERT PHILLIPS</p>  <p>TXDTIPH</p> <p>DRIVE BIT 1/4 S2 ALLOY TITANIUM NITRIDE</p>	<p>POWER HEX</p>  <p>TXDTPHX</p> <p>DRIVE BIT 1/4 S2 ALLOY TITANIUM NITRIDE</p>	<p>POWER PHILLIPS</p>  <p>TXDTPPH</p> <p>DRIVE BIT 1/4 S2 ALLOY TITANIUM NITRIDE</p>	<p>DOUBLE ENDED PHILLIPS</p>  <p>TXDDDPH</p> <p>DRIVE BIT 1/4 S2 ALLOY STEEL STANDARD</p>	<p>INSERT BIT HOLDER</p>  <p>TXDDIBH</p> <p>DRIVE BIT 1/4 S2 ALLOY STEEL STANDARD</p>	<p>INSERT HEX</p>  <p>TXDDIHX</p> <p>DRIVE BIT 1/4 S2 ALLOY STEEL STANDARD</p>	<p>INSERT PHILLIPS PLASTERBOARD</p>  <p>TXDDIPD</p> <p>DRIVE BIT 1/4 S2 ALLOY STEEL STANDARD</p>
<p>INSERT PHILLIPS</p>  <p>TXDDIPH</p> <p>DRIVE BIT 1/4 S2 ALLOY STEEL STANDARD</p>	<p>INSERT SLOTTED</p>  <p>TXDDISL</p> <p>DRIVE BIT 1/4 S2 ALLOY STEEL STANDARD</p>	<p>INSERT SQUARE</p>  <p>TXDDISQ</p> <p>DRIVE BIT 1/4 S2 ALLOY STEEL STANDARD</p>	<p>POWER HEX</p>  <p>TXDDPHX</p> <p>DRIVE BIT 1/4 S2 ALLOY STEEL STANDARD</p>	<p>MAGNETIC NUT SETTER</p>  <p>TXDDPNS</p> <p>DRIVE BIT 1/4 S2 ALLOY STEEL STANDARD</p>	<p>POWER PHILLIPS</p>  <p>TXDDPPH</p> <p>DRIVE BIT 1/4 S2 ALLOY STEEL STANDARD</p>	<p>POWER SLOTTED</p>  <p>TXDDPSL</p> <p>DRIVE BIT 1/4 S2 ALLOY STEEL STANDARD</p>
<p>POWER SQUARE</p>  <p>TXDDPSQ</p> <p>DRIVE BIT 1/4 S2 ALLOY STEEL STANDARD</p>	<p>POWER TRILOBULAR</p>  <p>TXDDPTR</p> <p>DRIVE BIT 1/4 S2 ALLOY STEEL STANDARD</p>	<p>POWER TORX</p>  <p>TXDDPTX</p> <p>DRIVE BIT 1/4 S2 ALLOY STEEL STANDARD</p>	<p>EZBIT DRILL BIT KIT</p>  <p>TXDEZPK</p> <p>PRE-DRILL & COUNTERSINK</p>		<p>EZBIT DRILL BIT REPLACEMENT</p>  <p>TXDEZRK</p> <p>PRE-DRILL & COUNTERSINK</p>	

MAGNET BOOSTER



TXDMB

DRIVE BIT 1/4 MAGNETIC BOOSTER

NEW WING NUT TENSIONER

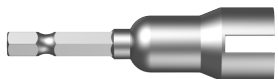

TXDDPWN

DRIVE BIT 1/4 S2 ALLOY STEEL STANDARD

Wing Nut Tensioner

Used to tension HDG Strap Tensioner GSTMGFW30.





RiVIX[®]



Dome and countersunk rivets

RIVET DOME HEAD OPEN R9P73OAS ALUM 5052 STEEL ZP	RIVET DOME HEAD OPEN R9P73O6S ALUM 5056 STEEL ZP	RIVET DOME HEAD OPEN R9P73OAA ALUM 5052	RIVET DOME HEAD OPEN R9P73OMS MONEL STEEL ZP	RIVET DOME HEAD OPEN R9P73OSS STEEL ZP	RIVET DOME HEAD OPEN R0473OLL 304 STAINLESS STEEL	RIVET DOME HEAD OPEN R0473OLS 304 STAINLESS STEEL STEEL ZP
RIVET DOME HEAD OPEN R1673OLL 316 STAINLESS STEEL	RIVET DOME HEAD LARGE FLANGE R9P73LAS ALUM 5052 STEEL ZP	NEW RIVET DOME HEAD LARGE FLANGE R0473LLL 304 STAINLESS STEEL	RIVET DOME HEAD SEALED R9P73TAP ALUMINIUM STEEL PHOS	RIVET DOME HEAD SEALED R9P73TCP COPPER STEEL PHOS	RIVET DOME HEAD SEALED R9673T6S ALUM 5056 STEEL ZP	RIVET DOME HEAD SEALED R0473TLL 304 STAINLESS STEEL
RIVET DOME HEAD PEEL R9673P6S ALUM 5056 STEEL ZP	RIVET DOME HEAD MULTI-GRIP R9P73MAS ALUM 5052 STEEL ZP	RIVET CSK OPEN R9P72OAS ALUM 5052 STEEL ZP	RIVET CSK OPEN R9P72OMS MONEL STEEL ZP	NEW RIVET CSK OPEN R9P72OSS STEEL ZP	RIVET CSK OPEN R0472OLL 304 STAINLESS STEEL	NEW RIVET CSK SEALED R9P72TAP ALUMINIUM STEEL PHOS



NEW

Rivet Nuts

<p>NEW RIVET NUT FLAT RND KNURL OPEN</p> <p>316</p>  <p>NR16PFKOM</p> <p>316 STAINLESS STEEL</p>	<p>NEW RIVET NUT FLAT RND KNURL OPEN</p>  <p>NRALPFKOM</p> <p>ALUMINIUM</p>	<p>NEW RIVET NUT FLAT RND KNURL OPEN</p>  <p>NRMSZFKOM</p> <p>Z/P</p>
--	---	---

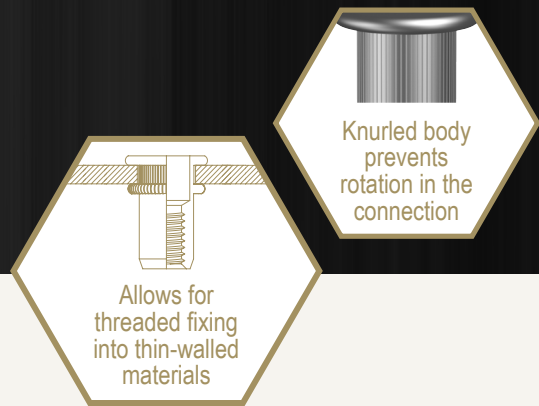

Rivet Head Types

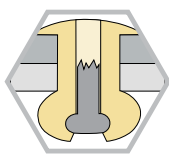

DOME HEAD OPEN

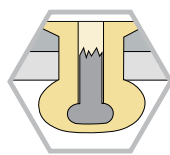

COUNTERSUNK SEALED

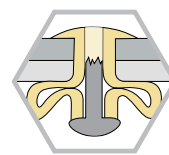

DOME HEAD TRIFORM

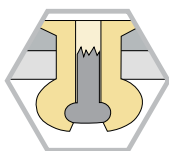

COUNTERSUNK OPEN

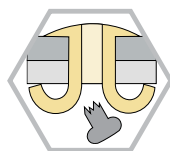

DOME HEAD PEEL

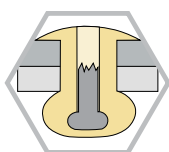

DOME HEAD SEALED

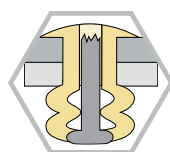

DOME HEAD MULTI-GRIP

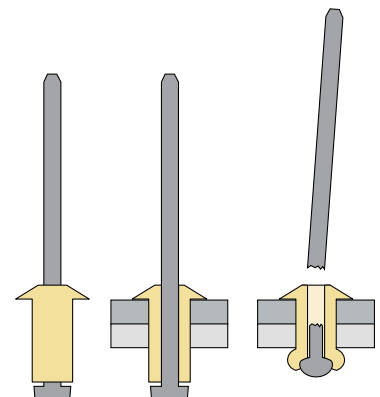



HOBSON



BOLT, NUT AND WASHER KITS

AGPACKS

**UNC
BOLT & NUT**



FEAG001
Z/P
GRADE 5 & 8
660 PIECES

**UNC
BOLT & NUT**



FEAG002
Z/P
GRADE 8
110 PIECES

**METRIC
BOLT & NUT**



FEAG003
Z/P
CLASS 8.8 & CLASS 8
650 PIECES

**ROUND
WASHERS**



FEAG004
Z/P
FLAT ROUND & SPRING
1275 PIECES



Strong plastic tub with resealable lid.



Keep one in your shed, ute or van.

All bolts, nuts and washers are zinc plated.

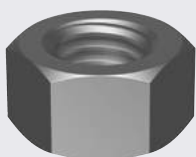

NUTS

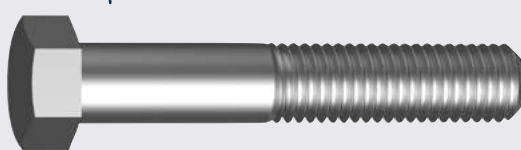

BOLTS



WASHERS

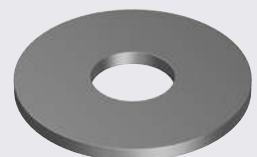

FASTENER KITS

Assortment Kits



All available in a tough, handy metal case.

SERRATED FLANGE BOLT & NUT CLASS 8.8



FEFK003

Z/P
M5 M6 M8 M10
12-50MM

HEX BOLT & NUT CLASS 8.8



FEFK004

Z/P
FINE M8 M10 M12
20-50MM

HEX BOLT NUT & WASHER

316



FEFK005

316 STAINLESS
M5 M6
12-25MM

HEX BOLT NUT & WASHER

316



FEFK006

316 STAINLESS
M8 M10
16-40MM

FLAT ROUND & SPRING WASHER



FEFK007

Z/P
M5 M6 M8 M10 M12

SOCKET HEAD CAP SCREW CLASS 12.9



FEFK008

PLN
M5 M6 M8 M10
10-50MM

RIVET DOME HEAD



FEFK010

ALUMINIUM / STEEL
3.2 4.0 4.8
6-15MM

METAL SELF-DRILLING SCREW



FEFK011

ZYP
8G 10G 12G
16-25MM

SELF-TAPPING PAN HEAD PHILLIPS



FEFK012

Z/P
6G 8G 10G 12G
9-50MM

HEX BOLT & NUT CLASS 8.8



FEFK015

Z/P
M6 M8 M10 M12
20-50MM

HEX BOLT & NUT GRADE 5 & 8



FEFK016

Z/P
UNC 1/4 5/16 3/8 1/2
3/4-2 INCH

HEX BOLT NUT SHCS & WASHER CLASS 8.8 & 12.9 FLANGE

M5



FEFK019

Z/P & PLN
M5
12-25MM

HEX BOLT NUT & WASHER CLASS 8.8

M6



FEFK020

Z/P
M6
12-40MM

HEX BOLT NUT & WASHER CLASS 8.8

M8



FEFK021

Z/P
M8
16-50MM

HEX BOLT NUT & WASHER CLASS 8.8

M10



FEFK022

Z/P
M10
16-65MM

HEX BOLT NUT & WASHER CLASS 8.8

M12



FEFK023

Z/P
M12
25-65MM



HOBSON



HOBSON

Merchandising & more

NEW CLAWBOLT HOODIE

ascolour.
CLAWBOLT



MKXAH5102C

COTTON / POLYESTER
AS COLOUR
STENCIL HOOD 5102

NEW HOBSON UMBRELLA



Soft EVA foam
handle grip

MKXPUHS190TNV

SHOWER PROOF POLYESTER
HYDRA SPORTS 190T

HOBSON HANDBOOK BOLTING



MKSCP-HBB-HEC

110 x 60mm
POCKET BOOK

Find these 5 products
in the product type:



OTHER

hobson.com.au

SHRINK WRAP



XSWB50025400

BLACK
25µm
500mm x 400m

THREAD CHECK DISPLAY



XXTHREADCHECK

WALL MOUNT
IMPERIAL / METRIC

THREAD CHECK DISPLAY CABLE



XXTHREADCHKCAB-I

ZIP
IMPERIAL

THREAD CHECK DISPLAY CABLE



XXTHREADCHKCAB-M

ZIP
METRIC

Featured in the **NEW** product type:



**HOBSON
MERCHANDISE**

hobson.com.au

Our Brand **Icons**

	APPLIED BOLTING®		H9 IMPACT™		TDX®
	BI-FIX®		IMPAX®		TITAN™
	BUMAX®		JMAX™		TONE®
	CLAWBOLT®		MUNGO®		TRADE PAX™
	CLAWBOLT® PRO		NEPTUNE®		TX-CON®
	CONXTRACT®		NORD-LOCK®		TYGABOLT®
	CONXTRACT® PRO		NYLOC®		TYKOTE®
	DECK MASTER®		RIVX®		VMAX®
	D-LOK®		SAMPSONROD®		WALLKATT®
	DRILLX®		SCHNORR®		XBOLT®
	H-IT®		SCRATCHGUARD®		XBOLT® PRO
	H-IT® PRO		SOKO®		XGRIP®

Visit our **NEW** website!

hobson.com.au



20 Categories



Choose by category or by product type



Weekly **Did You Know** flyers

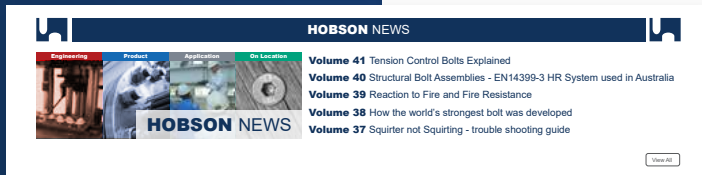

Newsletters

Product Search

Certificates online

35,000+ products online

Digital Product Guide

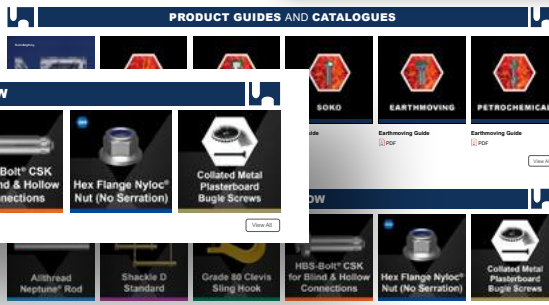
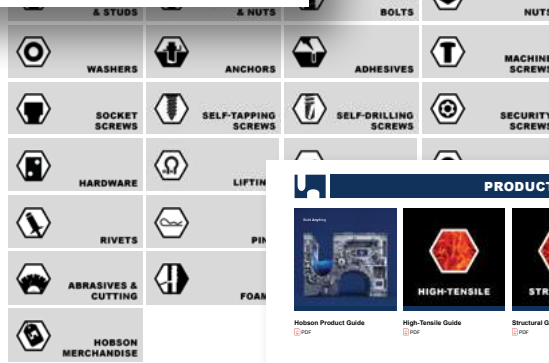

HOBSON ARTICLES

- » ASTM A325/M Weathering Steel Structural Assemblies
- » Reduced Loadability of Countersunk Head Cap Screws
- » Cyclone Screw Testing
- » Common Misconceptions About Stainless Steel
- » Changes to AS 4100 and AS/NZS 5131

Articles

SOLUTION ENGINEERING



NYLOC

DRILLX

SCHNORR

Bi-FIX

BUMAX



CONSTRUCT

NORD-LOCK GROUP



RIVX



WALLKATT



H9 IMPACT

XBolt



CLAWBOLT

DECK MASTER

impax





Quality Fasteners

Since 1935

Sydney

10 Clay Place
Eastern Creek
NSW 2766
Ph: (02) 8818 0222

Brisbane

56 Axis Place
Larapinta
QLD 4110
Ph: (07) 3273 0777

Melbourne

49-61 Marconi Drive
Dandenong South
VIC 3175
Ph: (03) 9797 3333

Perth

133 Beringarra Ave
Malaga
WA 6090
Ph: (08) 9241 9888

Newcastle

50 Elwell Close
Beresfield
NSW 2322
Ph: (02) 8818 0255

Townsville

Unit 2 788 Ingham Road
Mount Louisa
QLD 4814
Ph: (07) 3273 0733

Adelaide

1-5 Caribou Drive
Direk
SA 5110
Ph: (08) 9241 9899



MEMBERSHIP - Founding Member



MEMBERSHIP



CERTIFICATION



ACCREDITATION